

SERVICE MANUAL

Model

EX30

ENGINES

PUB-ES2268
Rev. 10/06

Robin America, Inc.

940 Lively Blvd. • Wood Dale, IL 60191 • Phone: 630-350-8200 • Fax: 630-350-8212
e-mail: sales@robinamerica.com • www.robinamerica.com

© Copyright 2006 Robin America, Inc.

CONTENTS

<i>Section</i>	<i>Title</i>	<i>Page</i>
1.	SPECIFICATIONS	1
2.	PERFORMANCE	2
3.	FEATURES	4
4.	GENERAL DESCRIPTION OF ENGINE COMPONENTS	5
5.	DISASSEMBLY AND REASSEMBLY	11
5-1	PREPARATIONS AND PRECAUTIONS	11
5-2	SPECIAL TOOLS	11
5-3	DISASSEMBLY PROCEDURE	12
5-4	REASSEMBLY PROCEDURE	26
6.	ENGINE OIL	42
7.	MAGNETO	43
8.	WIRING DIAGRAM	45
9.	ELECTRIC STARTER	47
10.	OIL SENSOR	49
11.	AUTOMATIC DECOMPRESSION SYSTEM	50
12.	CARBURETOR	51
13.	RECOIL STARTER	55
14.	INSTALLATION	59
15.	TROUBLESHOOTING	61
16.	STANDARD REPAIR TABLES	67
16-1	STANDARD DIMENSIONS AND LIMITS OF USE	67
16-2	TIGHTENING TORQUE	73
17.	MAINTENANCE AND STORAGE	74

1. SPECIFICATIONS

MODEL	EX30D	
Type	Air-cooled, 4-cycle single cylinder, overhead camshaft, gasoline engine	
Displacement	mL (cc)	287
Direction of Rotation	Counterclockwise, as Viewed from P.T.O. Shaft side	
Lubricant	Automotive detergent oil (API/ SE or higher grade, SAE/ 10W-30 etc.)	
Oil Capacity	Liter	1.0
Fuel	Automotive Gasoline (Unleaded)	
Spark Plug	NGK BR-6HS	
Starting System	Recoil starter /Electric starter	
Dry Weight	kg	21
Dimensions (L x W x H)	mm 415 x 424 x 319	
Valve Clearance (Intake and Exhaust)	0.12 ^{+0.03} ₀ mm (0.0047 ^{+0.0012} ₀ in.)	
	Note : Adjust the valve clearance while the engine is cold.	
Emissions Durability Period (California only)	500 hours	

2. PERFORMANCE

2-1 MAXIMUM OUTPUT

The Maximum output is the output of an engine with its throttle valve fully opened and considering that all the moving parts are properly broken in.

A new engine may not produce full maximum output while its moving parts are still not broken-in.

NOTE :

Power curves shown in the following charts are made in conformity with SAE internal combustion engine standard test code J1349.

2-2 CONTINUOUS RATED OUTPUT

The continuous rated output is the output of an engine at optimum governed speed which is most favorable from the view point of engine's life and fuel consumption.

When the engine is installed on a certain equipment, it is recommended that the continuous output required from the equipment to be kept below this continuous rated output.

2-3 MAXIMUM TORQUE

The maximum torque is the torque at the output shaft when the engine is producing maximum output at a specific r.p.m..

2-4 PERFORMANCE CURVES

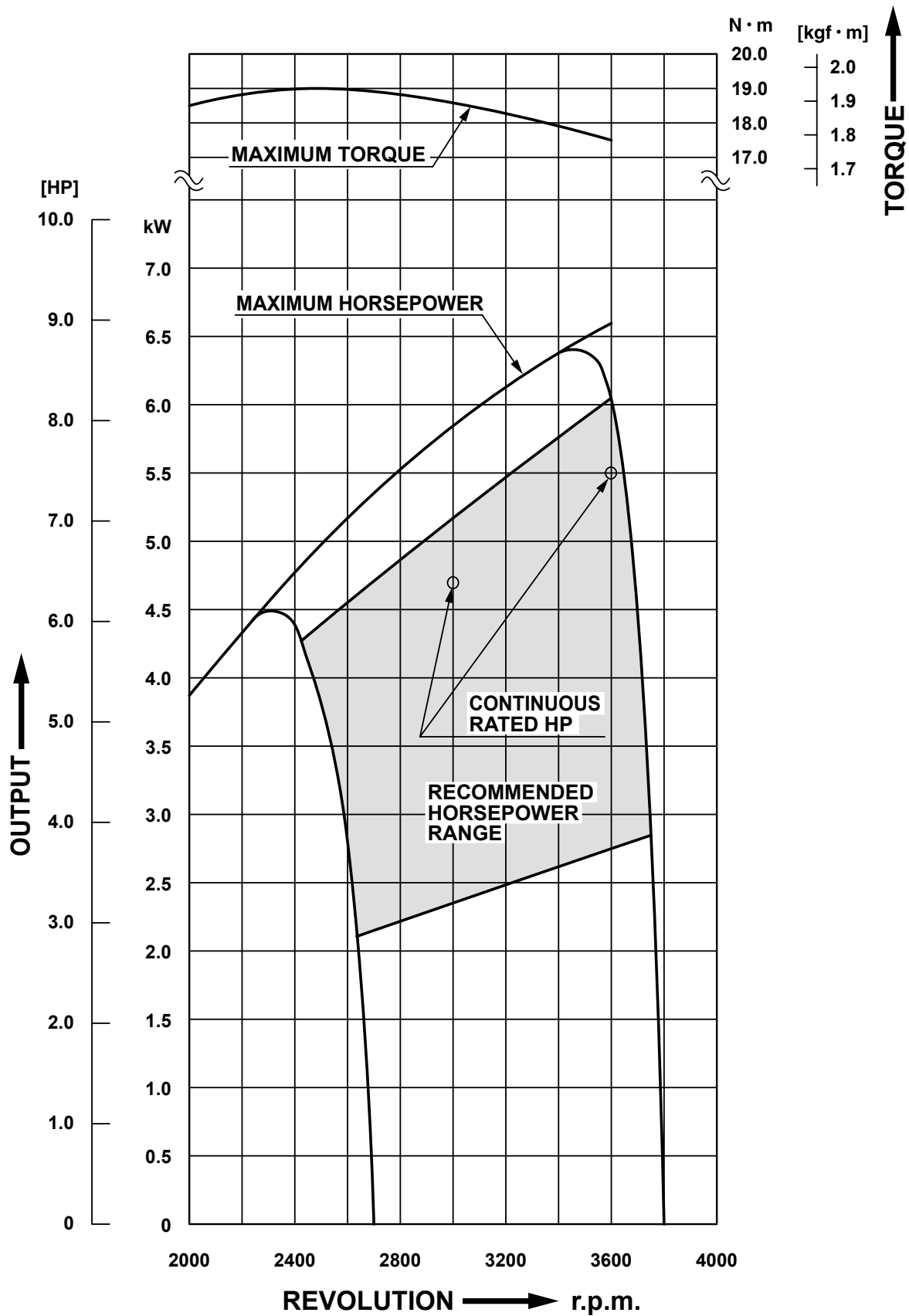

3. FEATURES

3-1 EXTREMELY EASY START - NO KICK-BACK

Reliable Starting and Less Pulling Force are achieved by:

- Sophisticated Mechanical Compression Release System as well as newly designed Combustion Chamber.
- EX engines start instantly even at minus (-) 10°C, without any perceptible kick-back.

3-2 EXTREMELY EASY MAINTENANCE

Extreme ease of maintenance is realized by:

- **Only with ordinary tools**, routine maintenance, assembly and disassembly can be performed.

3-3 EXTREMELY ADVANCED TECHNOLOGY

Extreme reliability and durability are achieved by:

- **Heavy Duty Chain Driven OHC System**
Oval type case-hardened steel links enhance performance and resist stretching, which result in extended maintenance free operation.
- **Completely New Main Bearing Cover's Design**
Flush-mounted main bearing cover with lower moment of deformation significantly increases reliability and engine life.
- **Superior Cooling and Lubrication System**
Heat reduction is achieved by more efficient, larger and more numerous cooling fins on crankcase, cylinder and mounting base, as well as by outstanding oil delivery system.
- **Large Ball Bearings** on both ends of crankshaft for maximum stability under demanding loads.
- **Cast Iron Cylinder Liner** resists wear

3-4 EXTREME POWER AND PERFORMANCE

Extremely Higher Power and Lower Fuel Consumption are realized by:

- High speed and homogeneous combustion achieved by sophisticated Pentroof Combustion Chamber which includes Intake and Exhaust Valves located at optimum angle.
- Straight Intake Port with minimal air flow resistance.

Environmentally friendly

EX engines comply with EPA Phase 2 and CARB Tier II Emission Regulations in the USA.

Extreme application compatibility

With four versatile models, existing slant-cylinder engines can be easily replaced.

4. GENERAL DESCRIPTION OF ENGINE COMPONENTS

4-1 CYLINDER AND CRANKCASE

The cylinder and crankcase are aluminum die-casting as a single piece. A special cast iron cylinder liner is molded into the aluminum die-casting.

The crankcase has a mounting surface on the output shaft side to which the main bearing cover is attached. The cylinder is inclined to the right at an angle of 25 degrees from the horizontal as viewed from the output shaft side.

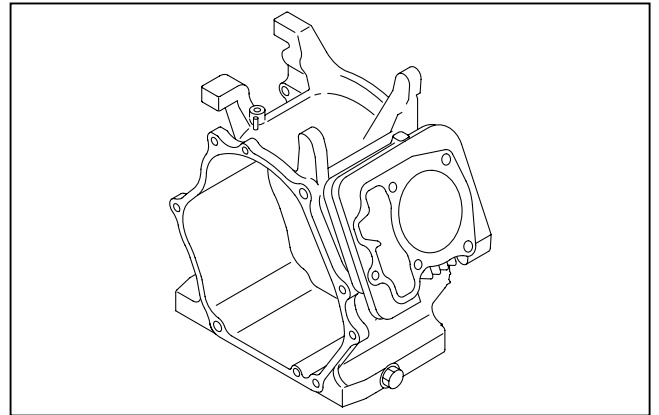

4-2 MAIN BEARING COVER

The main bearing cover is an aluminum die-casting, which is mounted on the output shaft side of the crankcase. By removing the main bearing cover, the inside of the engine can be inspected with ease. Pilots and bosses are machined into the cover to facilitate the direct coupling of the engine with machines such as generators and pumps. There is an oil filling port, with oil gauge, on either side of the cover.

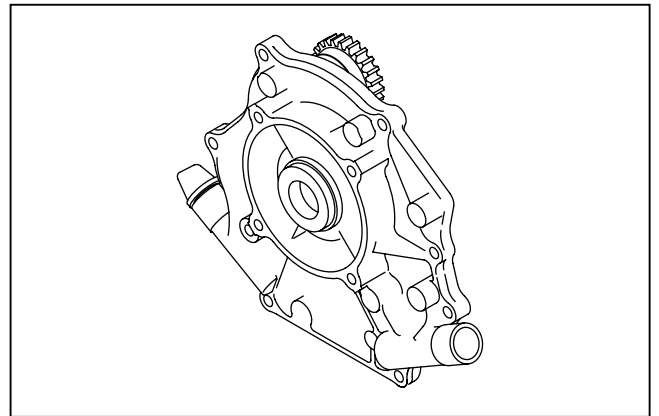

4-3 CRANKSHAFT

The crankshaft is made of spheroidal graphite cast iron, and the crank pin is high-frequency induction-hardened. The crank sprocket used to drive the chain and the gear used to drive the governor gear are pressed into the output end of the shaft.

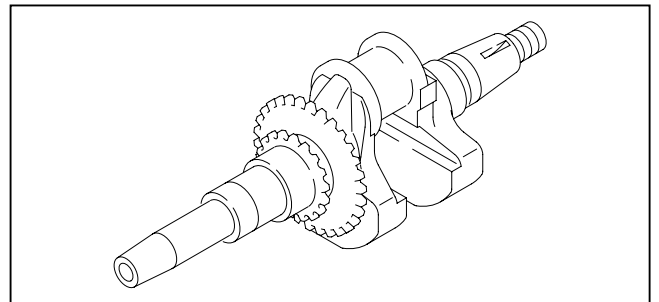

4-4 CONNECTING ROD AND PISTON

The connecting rod is a specially heat-treated aluminum alloy die-casting. Its large and small ends function as bearings. A splasher built into the connecting rod lubricates by splashing engine oil. The piston is an aluminum alloy casting with grooves for mounting two compression rings and one oil ring.

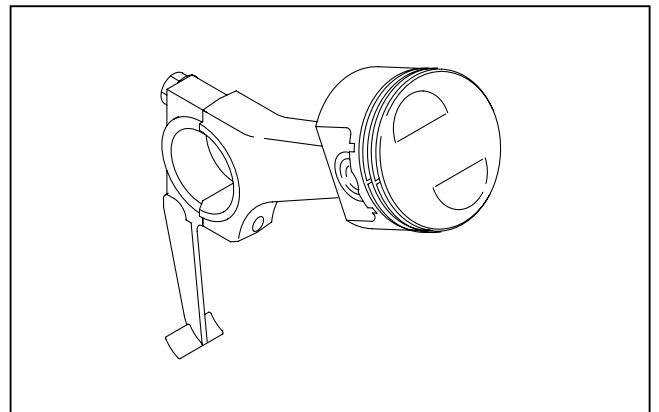

4-5 PISTON RINGS

The piston rings are made of special cast iron. The profile of the top ring is a barrel face or tapered face, and that of the second ring is a tapered face. There are 2 types of oil ring depending on the engine specification.

As those are interchangeable, the cutter ring with coil expander type can be selected as the spare part.

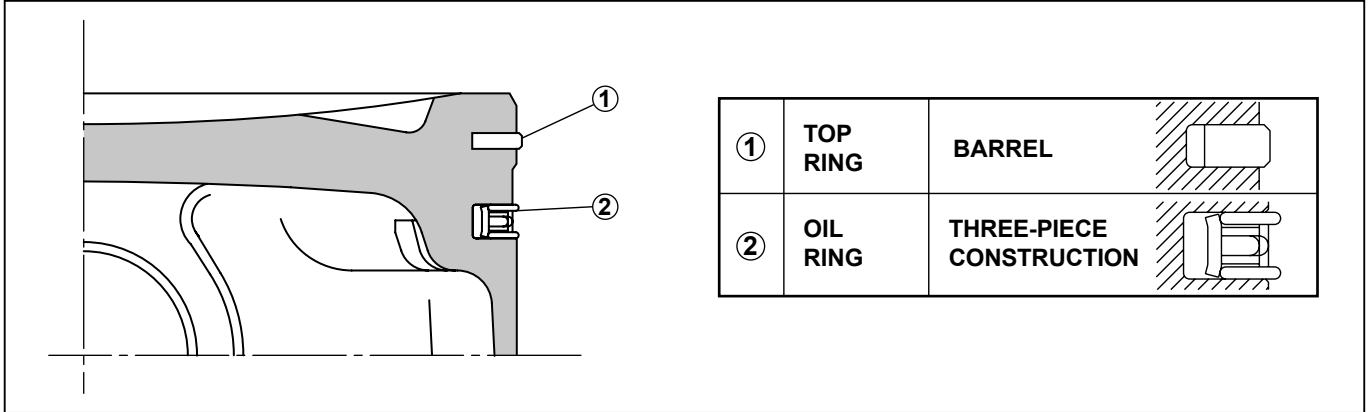

4-6 CAMSHAFT

The camshaft and the sprocket are made of special sintered alloy. They are constructed as a single piece. The camshaft is provided with intake and exhaust cam, and the decompression release lever is mounted on the sprocket shaft end side.

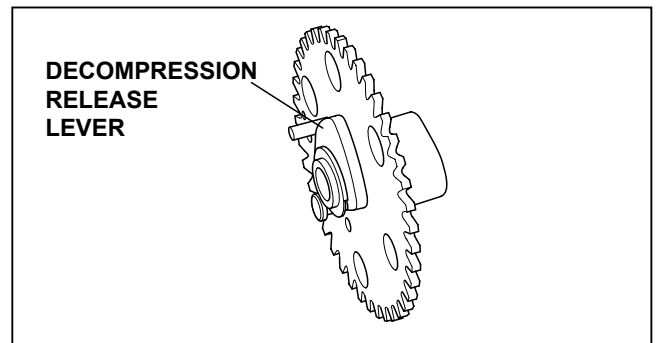

4-7 VALVE ARRANGEMENT

This engine has a chain-driven overhead cam and overhead valve construction, with a single cam performing both intake and exhaust operations.

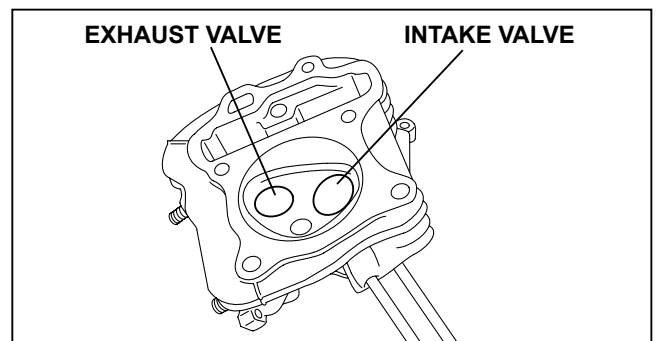

4-8 CYLINDER HEAD

The cylinder head is an aluminum die-casting with a pent roof combustion chamber construction. The intake and exhaust ports are arranged in a cross direction to improve combustion efficiency.

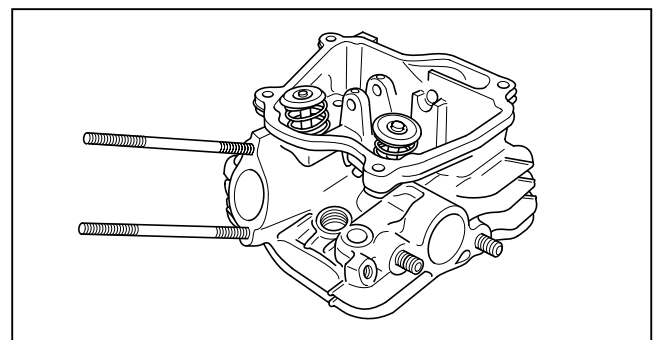

4-9 GOVERNOR SYSTEM

This engine is equipped with a centrifugal flyweight type governor that makes it possible to operate the engine at a constant speed, even with load variations. (The governor flyweights are mounted on a governor gear.)

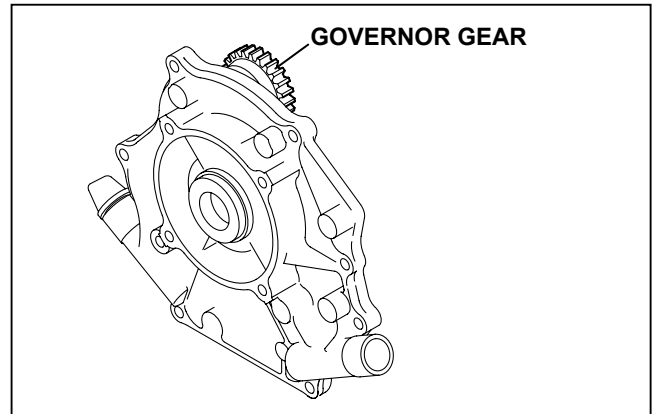

4-10 COOLING SYSTEM

The engine uses a forced air-cooling system in which a cooling fan (which also works as a flywheel) forces cooling air into the cylinder and the cylinder head. Baffles are provided to guide the flow of the cooling air.

4-11 LUBRICATION SYSTEM

The rotating parts, sliding parts and valves of the engine are lubricated with oil in the crankcase. The oil is splashed onto the parts by the oil splasher on the connecting rod.

4-12 TIMING CHAIN

Timing chain system is adopted and designed for lubricating for the upper portion of cylinder head.

The timing chain is engaged between the sprocket portion of integrated camshaft in the cylinder head and the crankshaft gear sprocket.

The sprocket teeth in particular shape are adopted to enhance the durability and to realize low noise level.

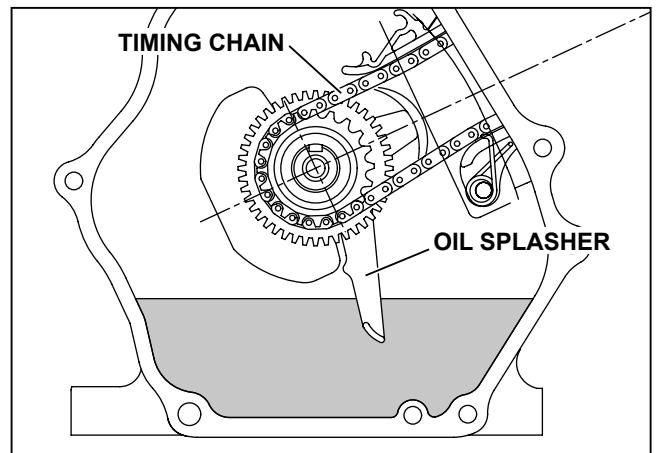

4-13 IGNITION SYSTEM

The ignition system is a transistor controlled magneto system with the ignition timing set at 23 degrees before the top dead center. The magneto consists of a flywheel and ignition coil. The flywheel (which also works as a fan) is directly mounted on the crankshaft and the ignition coil is directly mounted on the crankcase.

※Model EX30 has a smooth advanced ignition timing system to improve starting performance.

(For further details, refer to page 43, section "7. MAGNETO")

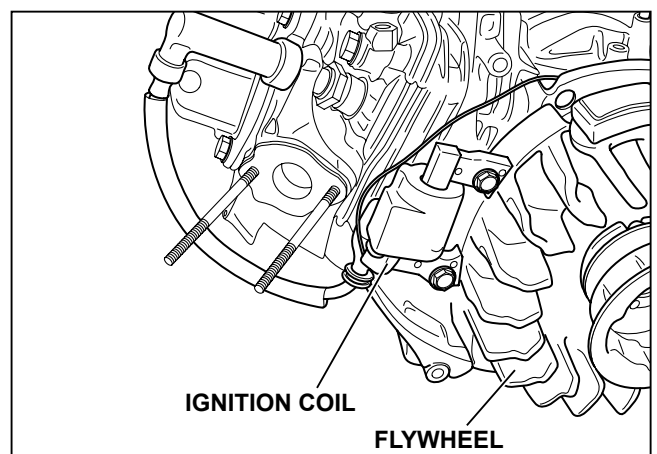

4-14 CARBURETOR

The engine is equipped with a horizontal draft carburetor. The carburetor setting is calibrated after careful testing for optimum all-round performance (including starting, acceleration, fuel consumption, output power characteristics). Special attention is also paid to the general-purpose use of the engine. (For further information, refer to page 51, section "12. CARBURETOR")

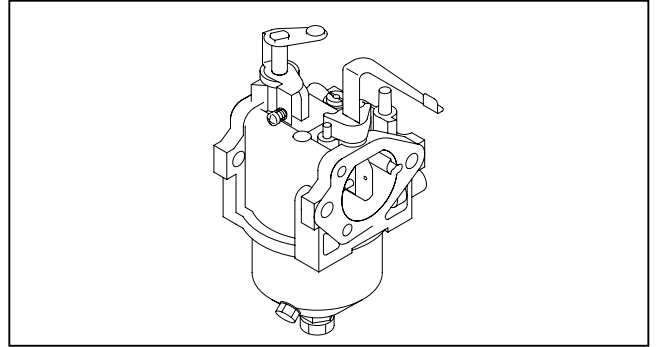

4-15 AIR CLEANER

The engine uses an air cleaner that is quieter than conventional ones. A semi-wet urethane foam element is used in the urethane foam air cleaner.

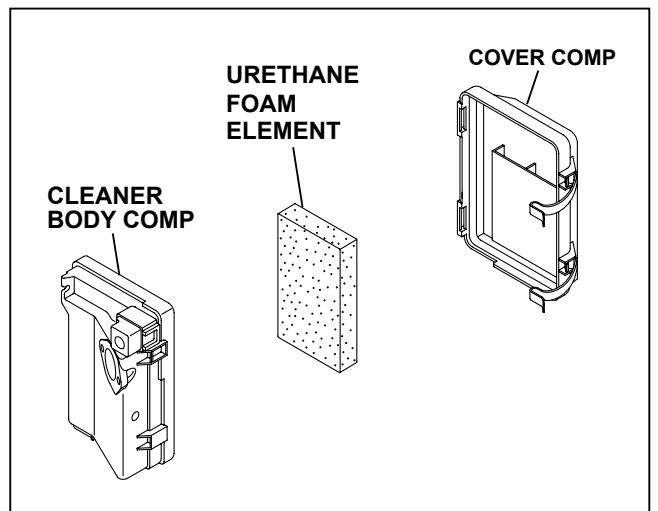

4-16 DECOMPRESSION SYSTEM

The automatic decompression system is mounted on the camshaft. It opens the exhaust valve before the compression top, thereby alleviating the compression pressure and reducing the force required to pull the recoil starter.

During engine operation, the decompression system is overpowered by centrifugal force and compression is fully utilized to produce power.

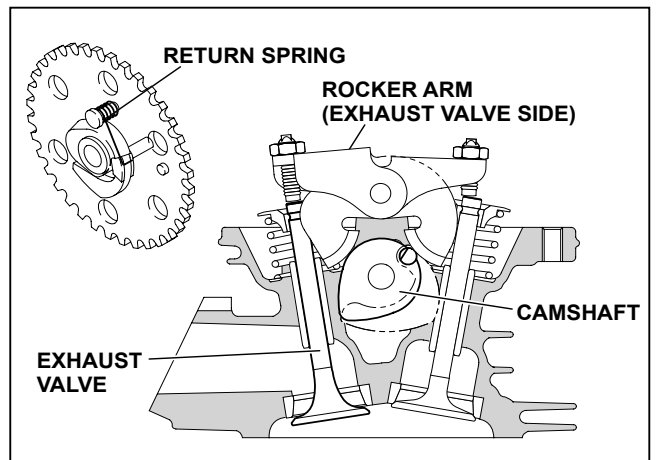

4-17 SECTIONAL VIEW OF THE ENGINE

Cross sectional view - across the shaft

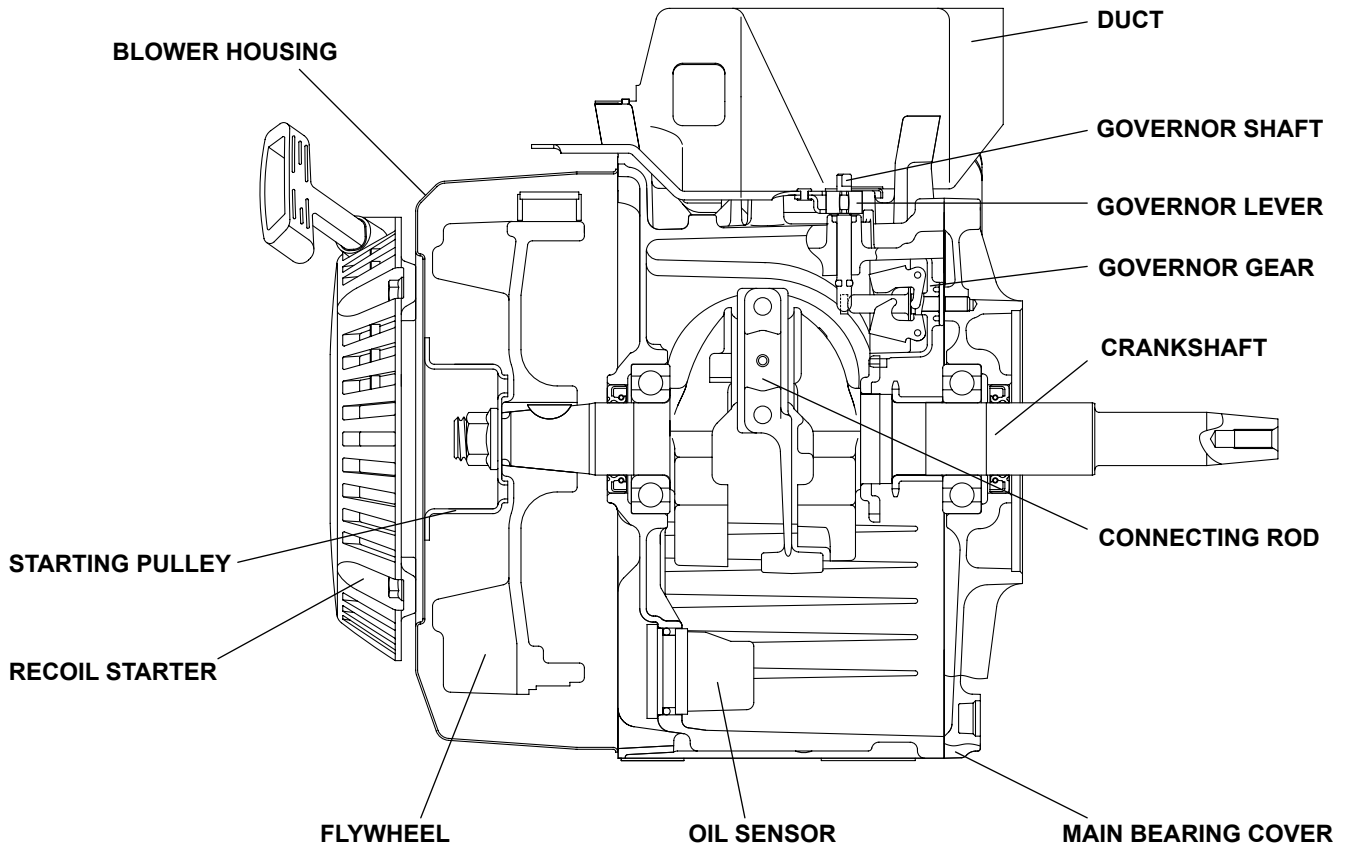

Cross sectional view - along the shaft

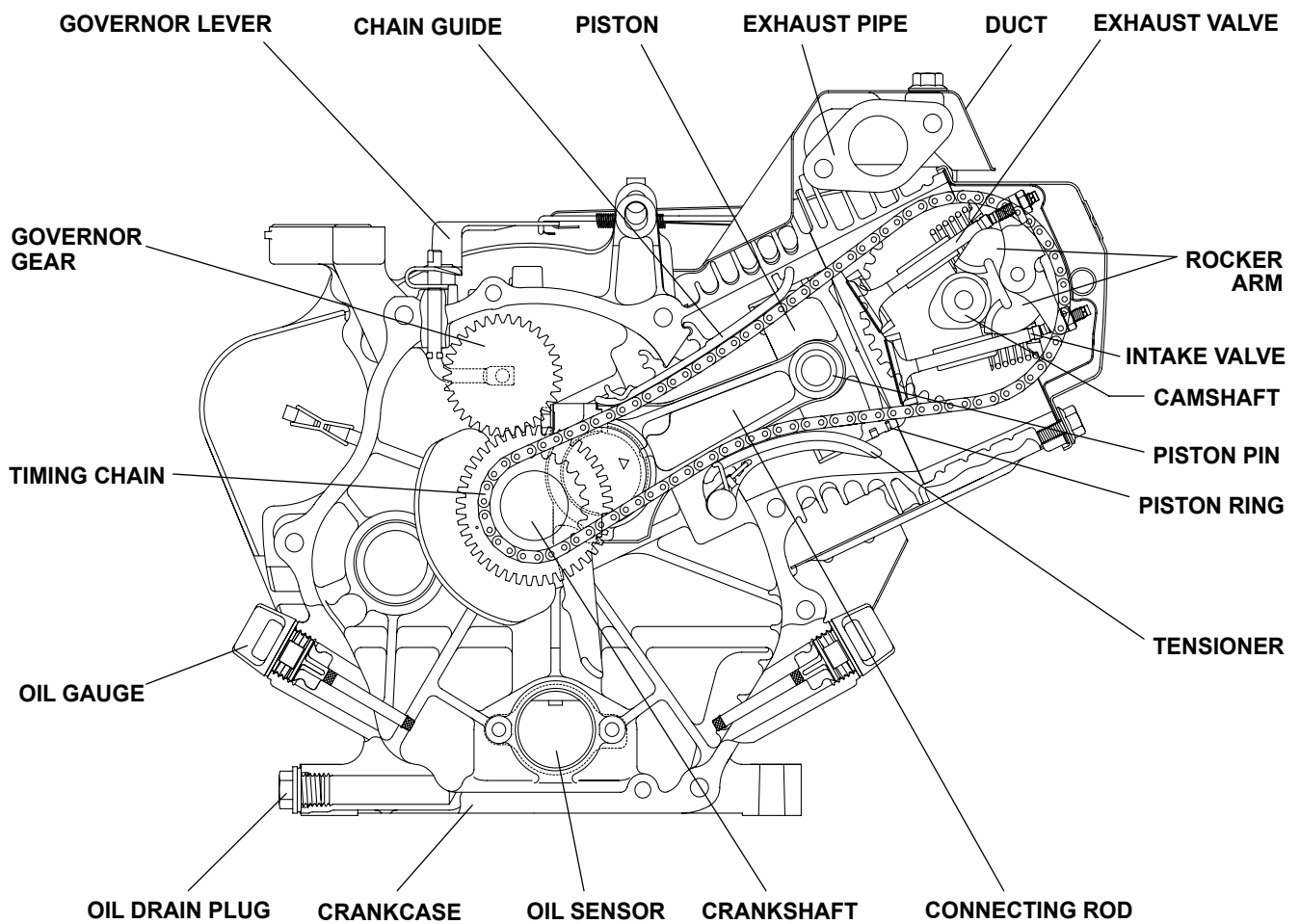

5. DISASSEMBLY AND REASSEMBLY

5-1 PREPARATIONS AND PRECAUTIONS

- (1) When disassembling the engine, memorize the location of each part so that you can reassemble the engine correctly. If necessary, attach identification tags with the required assembly information to the parts.
- (2) Store groups of parts in separate boxes. This will make reassembly easier.
- (3) To prevent parts from being mislaid, keep each group provisionally assembled after removing the parts from the engine.
- (4) Handle the disassembled parts with the utmost care. Clean them with cleaning oil if necessary.
- (5) Use the correct tools in the correct way when disassembling and reassembling the engine.

5-2 SPECIAL TOOLS

	Tool name	Use
Commercially available product	Flywheel puller	For pulling off the flywheel

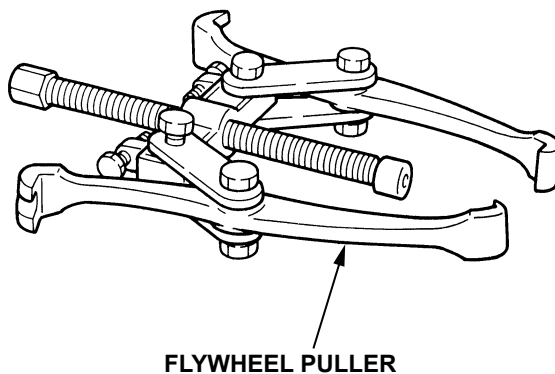

5-3 DISASSEMBLY PROCEDURE

Step	Parts to remove	Remarks and procedures	Fasteners
1	Drain the engine oil	(1) Remove a drain plug (M14 x 12mm) located on both sides of the case. Take care not to lose the gaskets. (2) To discharge oil quickly, remove the oil gauge.	14 mm spanner
2	Drain the fuel	(1) Drain fuel from the carburetor drain. (See Figure STEP2-A) (2) Disconnect the fuel pipe from the carburetor. (See Figure STEP2-B)	

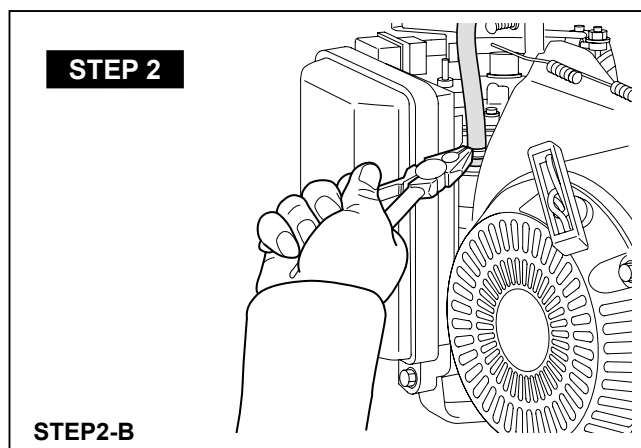
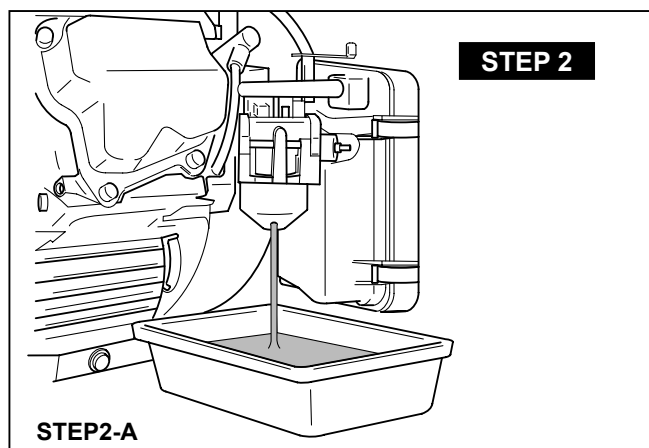
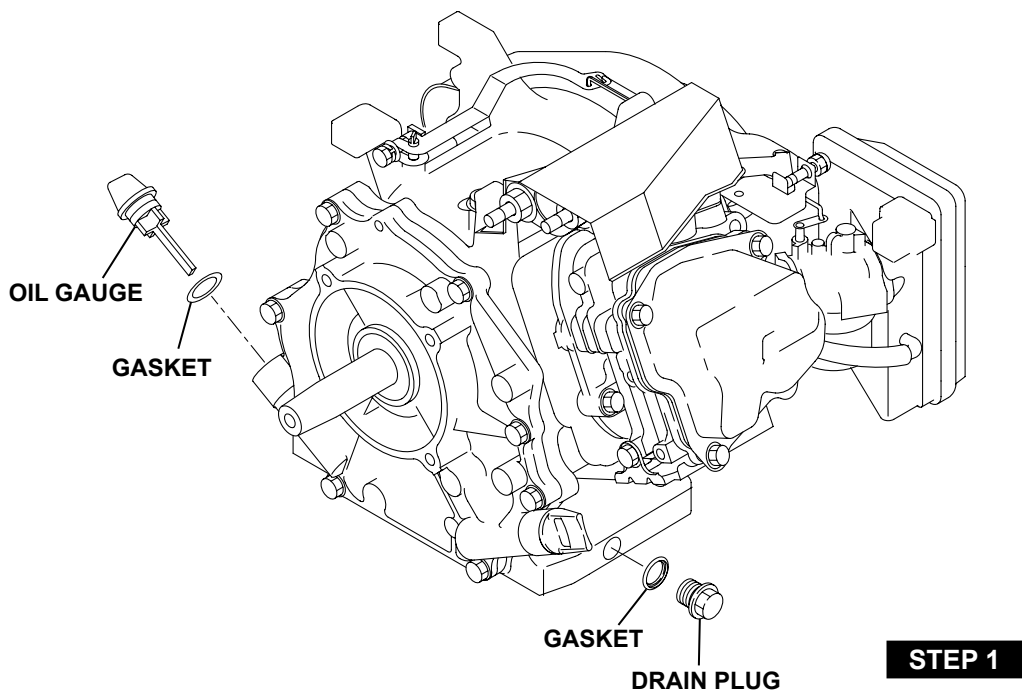

Step	Parts to remove	Remarks and procedures	Fasteners
3	Air cleaner cover	Remove the air cleaner cover.	14 mm spanner
4	Air cleaner	Remove the element, and remove the air cleaner while pulling the breather pipe away from the rocker cover.	10 mm box spanner M6 nut : 2 pcs. M6 x 20 : 1 pc.

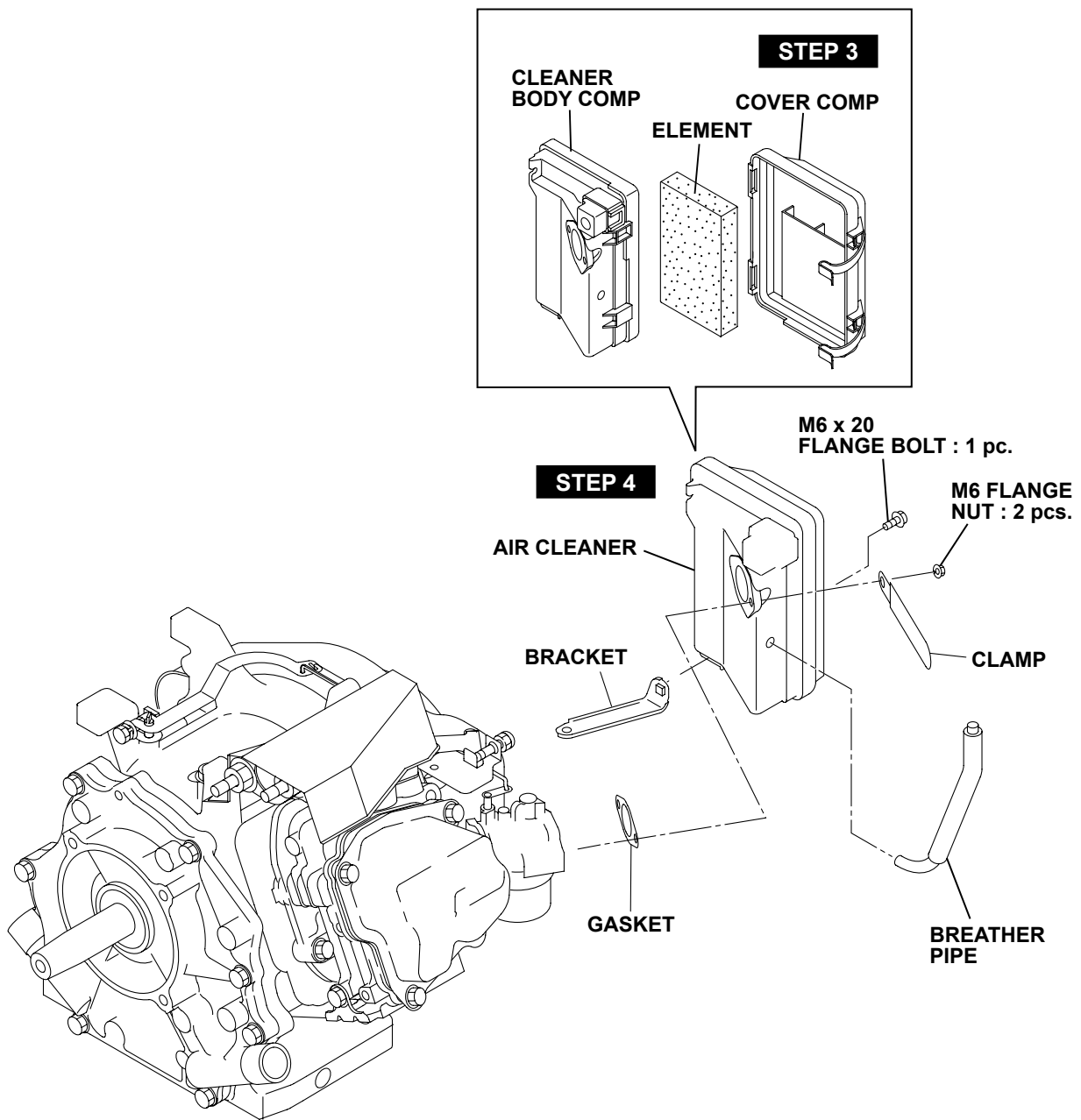

Step	Parts to remove	Remarks and procedures	Fasteners
5	Stop switch (Float C/U CP5)	Disconnect the wire and remove the stop switch from the blower housing.	
6	Recoil starter	Remove the recoil starter from the blower housing.	10 mm box spanner M6 x 14mm : 4 pcs.
7	Blower housing Baffle 1 (case) Baffle 2 (head)	(1)Remove the blower housing from the crankcase. (2)Remove the baffle 1 (case) and baffle 2 (head).	10 mm box spanner M6 x 14mm : 4 pcs. 10 mm box spanner or spanner M6 x 12mm : 1 pc. (Baffle 2 (head))

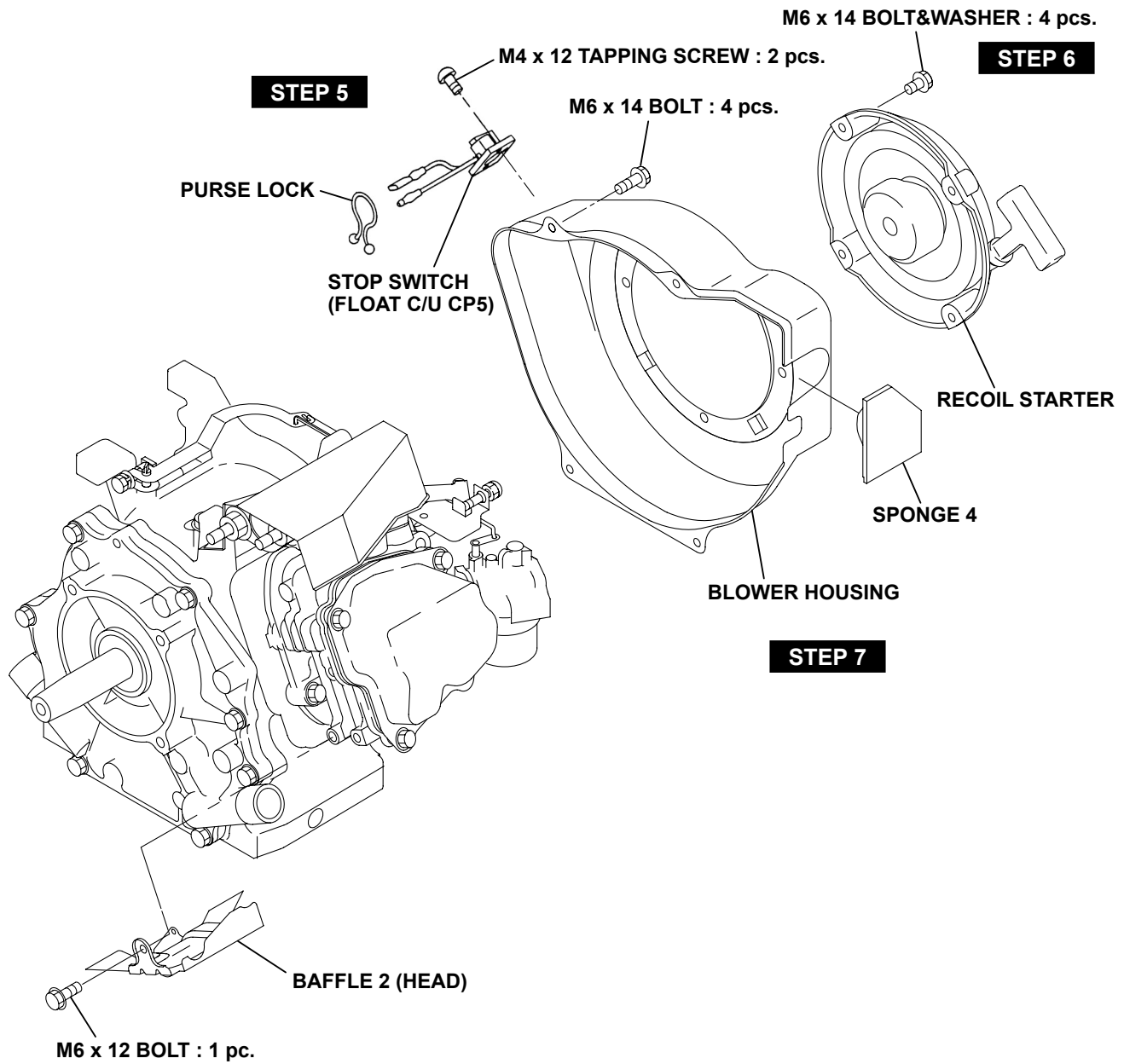

Step	Parts to remove	Remarks and procedures	Fasteners
8	Duct (case)	Remove the Duct (case) from the crankcase.	10 mm box spanner M6 x 12mm : 3 pcs
9	Exhaust pipe	Remove the Exhaust pipe from the cylinder head. Take care not to lose the gasket. ※ Take care not to cut your hand with the muffler gasket. ※ Seal the exhaust port with adhesive tape or plug it with cloth to prevent nuts and other objects from falling inside.	12mm box spanner M8 nut : 4 pcs.

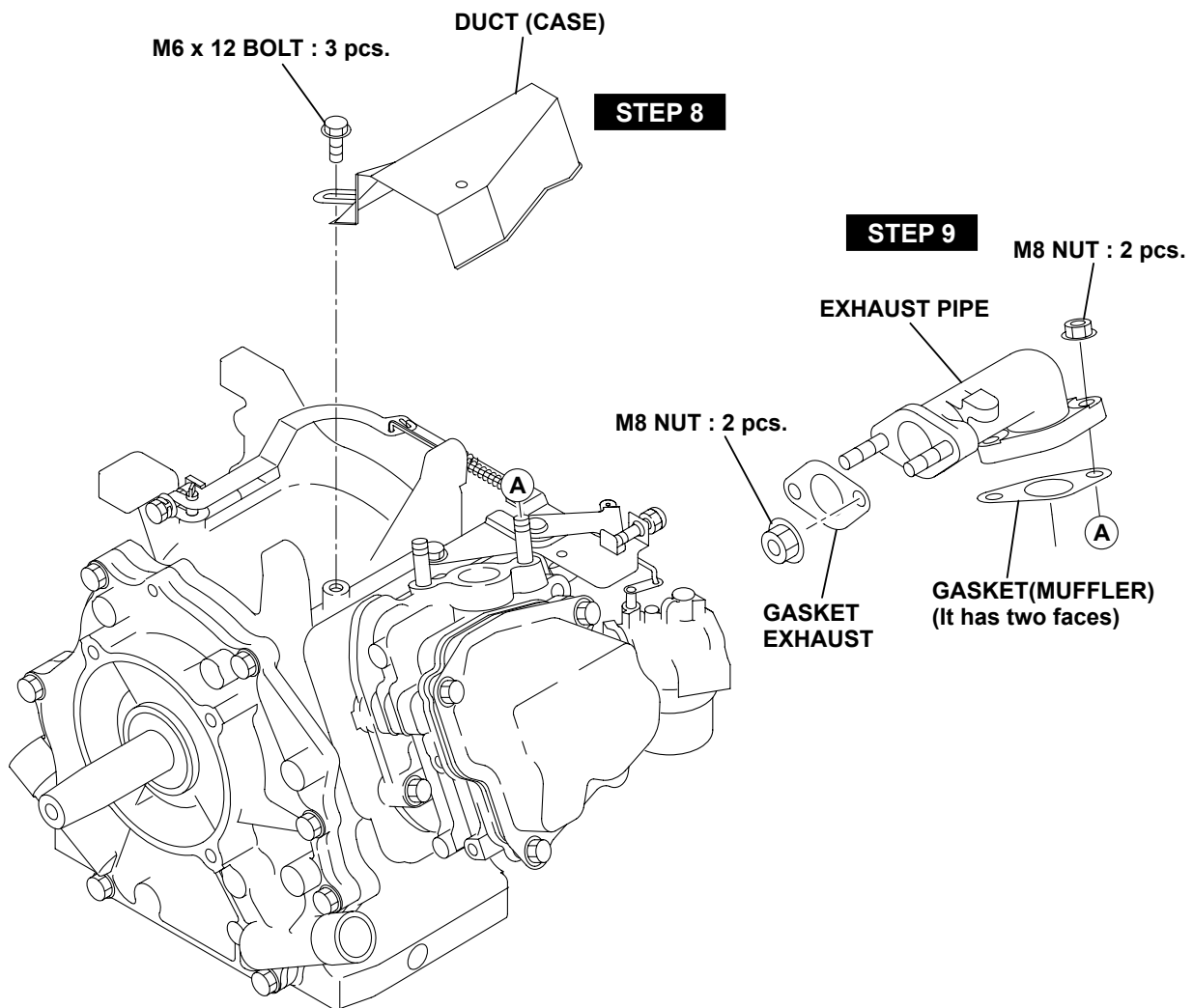

Step	Parts to remove	Remarks and procedures	Fasteners
10	Governor system	(1) Loosen the bolt and remove the governor lever from the governor shaft. There is no need to remove the bolt. (2) Remove the governor spring. (3) Remove the governor rod and the rod spring from the carburetor.	14 mm spanner
11	Carburetor, Insulator	(1) Remove the carburetor from the cylinder head. (2) Remove the insulator.	
12	Speed control lever and Bracket	Remove the speed control lever and bracket from the cylinder head.	10 mm box spanner M6 x 12mm : 2 pcs.

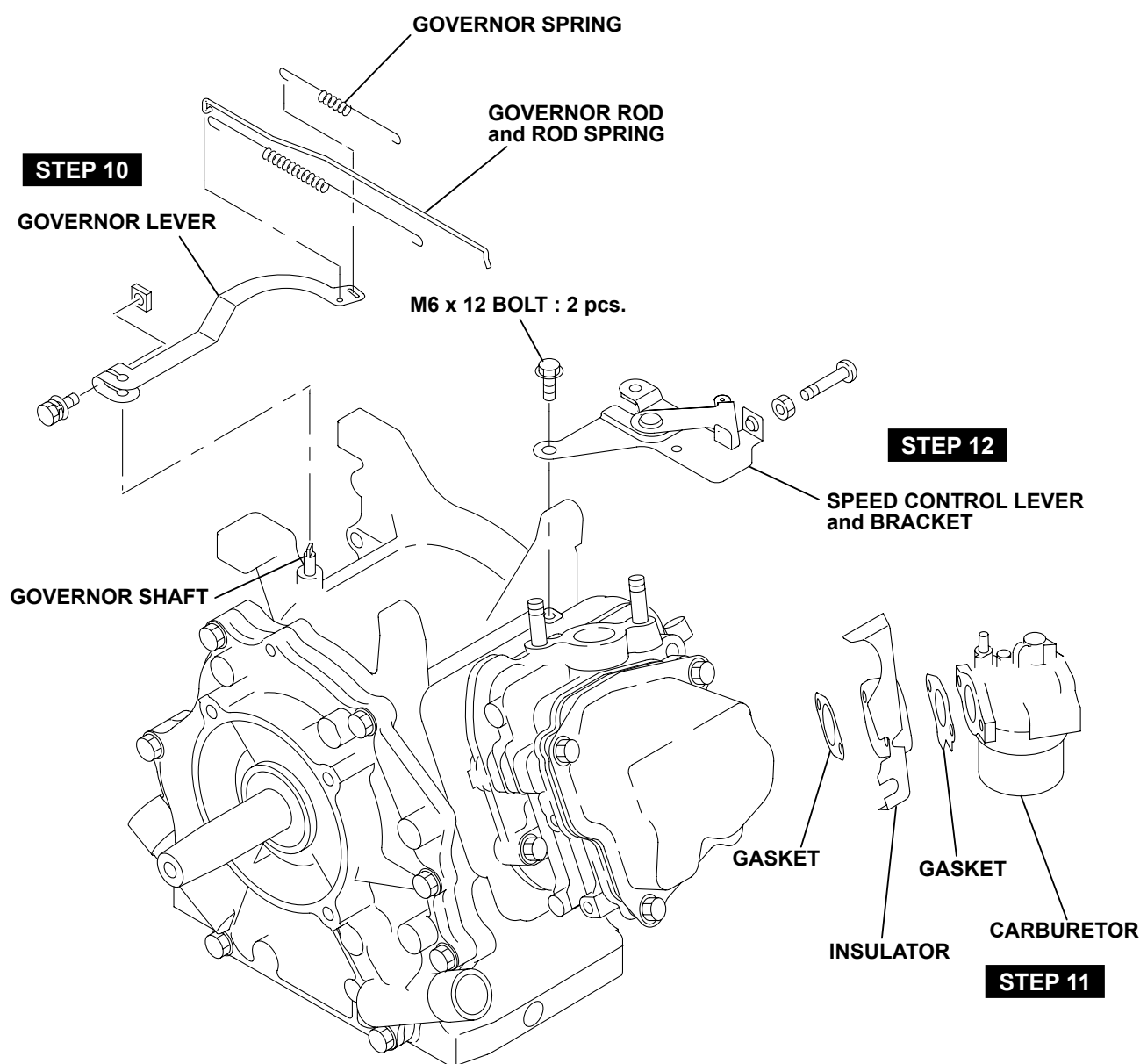

Step	Parts to remove	Remarks and procedures	Fasteners
13	Ignition coil	Remove the spark plug cap from the spark plug and remove the ignition coil from the crankcase.	10 mm box spanner M6 x 25mm : 2 pcs.
14	Starting pulley	Wear work gloves during operation to avoid a possible injury by a sharp edge. Remove the starting pulley from the flywheel. Fit a box wrench or a socket wrench on the flywheel nut and loosen the nut by knocking the wrench sharply with a hammer. (See Figure STEP14-A) NOTE: 1) Do not insert a screwdriver or other object between the flywheel blades, otherwise the risk of damaging the blades might be occurred. 2) Knock the wrench with a hammer in a counter clockwise direction.	24 mm box spanner or socket wrench M18 nut
15	Flywheel	Remove the flywheel from the crankshaft. Leave the nut temporarily to prevent the flywheel from dropping out. Fit the flywheel puller as shown in Figure STEP15-A and remove the flywheel from the crankshaft by rotating the bolt at the center in a clockwise direction. (Knock the center bolt with a hammer sometimes)	Flywheel puller

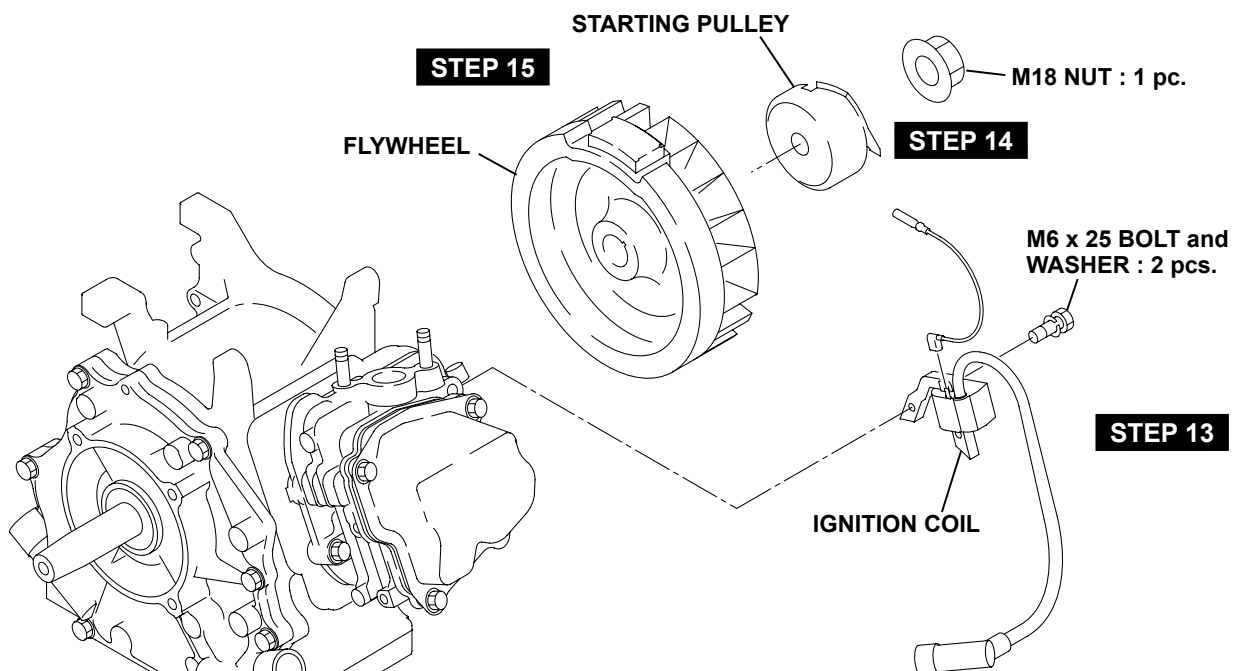
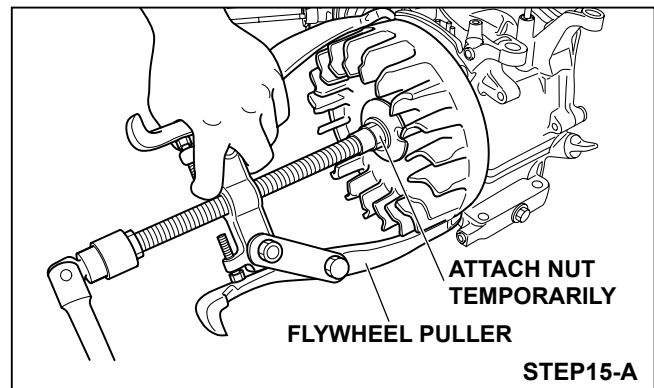
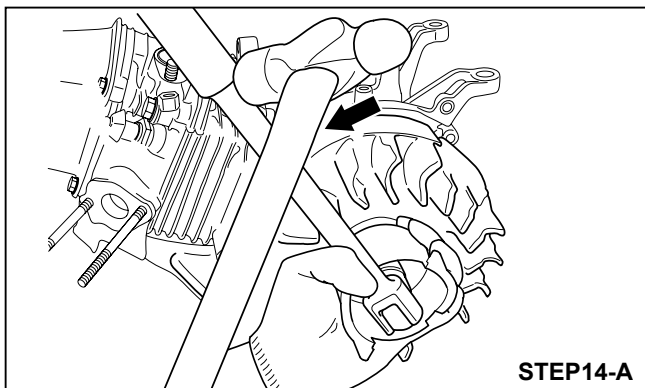

Step	Parts to remove	Remarks and procedures	Fasteners
16	Electric starter (option) Control box, Diode rectifier, Magnetic switch	(1) Disconnect the grounding cable from battery. (2) Disconnect the wire leading from the key switch "ST" terminal to the magnetic switch. (3) Disconnect the wire that connects the positive terminal of the battery to the magnetic switch. (4) Remove the electric starter.	12 mm box spanner M8 nuts 12 mm box spanner

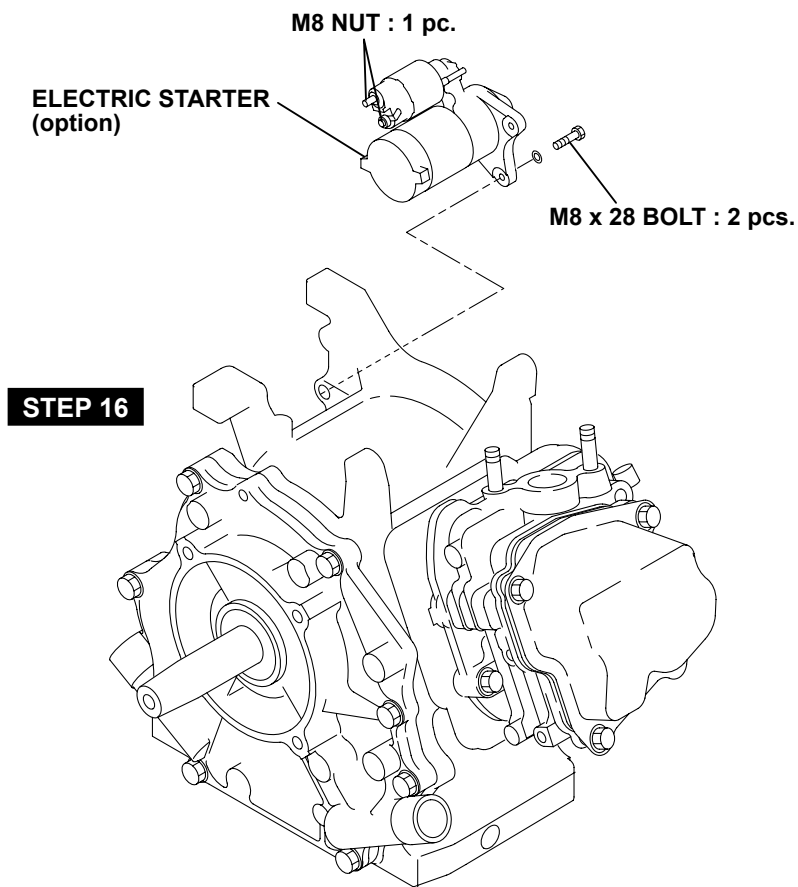

Step	Parts to remove	Remarks and procedures	Fasteners
17	Baffle 1 (case)	Remove the baffle 1 (case)	M8 x 12mm : 1 pc.
18	Charge coil (option)	Remove the charge coil. (Remove the wire clamp together)	box spanner M6 x 20mm : 2 pcs. + screwdriver
19	Spark plug	Remove the spark plug from the cylinder head.	21 mm plug wrench

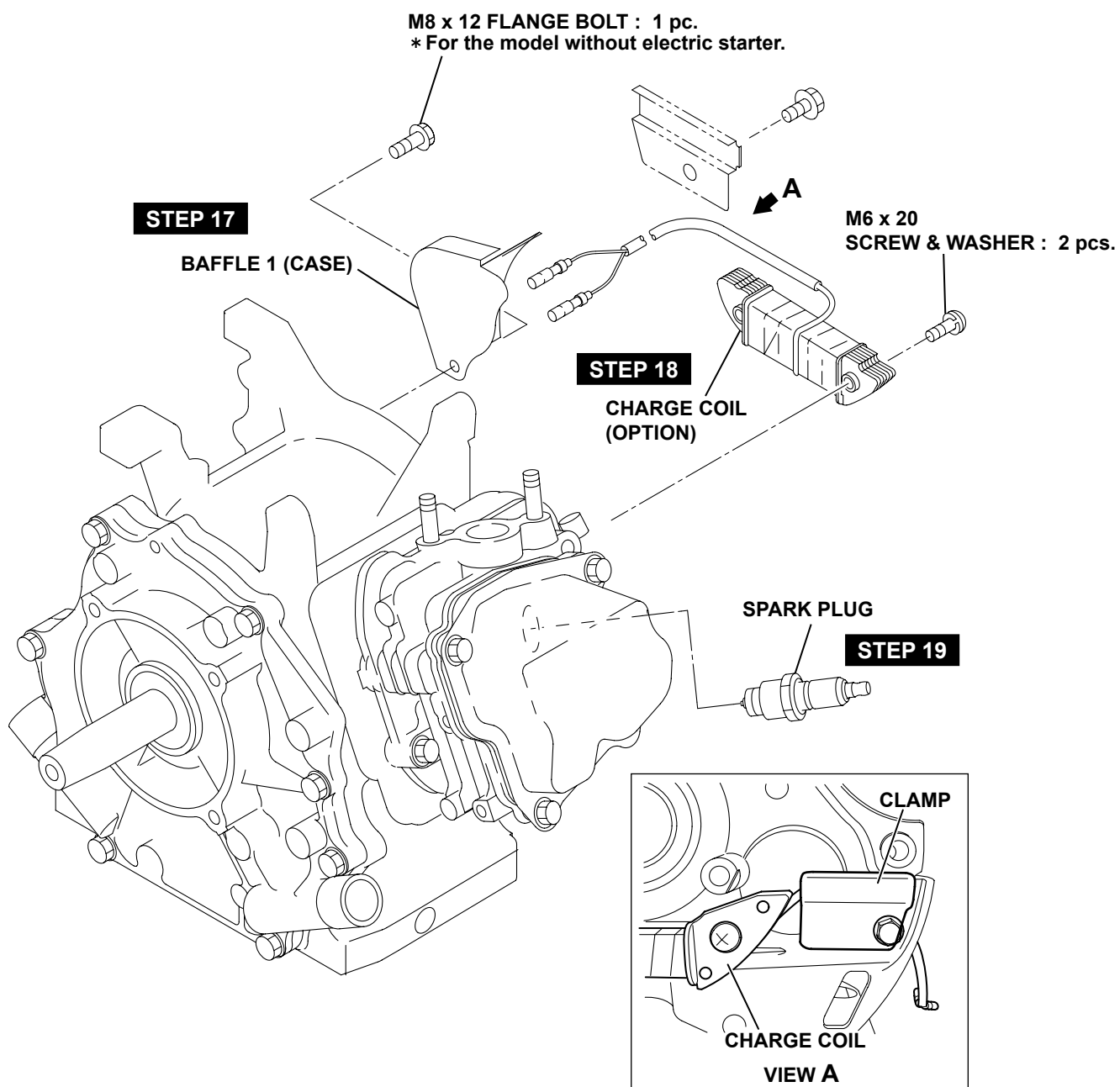

Step	Parts to remove	Remarks and procedures	Fasteners
20	Rocker cover	(1) Remove the rocker cover from the cylinder head. (2) Remove the gasket (rocker cover).	10 mm box spanner M6 x 12mm : 4 pcs.
21	Rocker arm	Remove the pin (rocker arm) and the rocker arm from the cylinder head at the compression top dead center. (See Figure STEP21-A)	

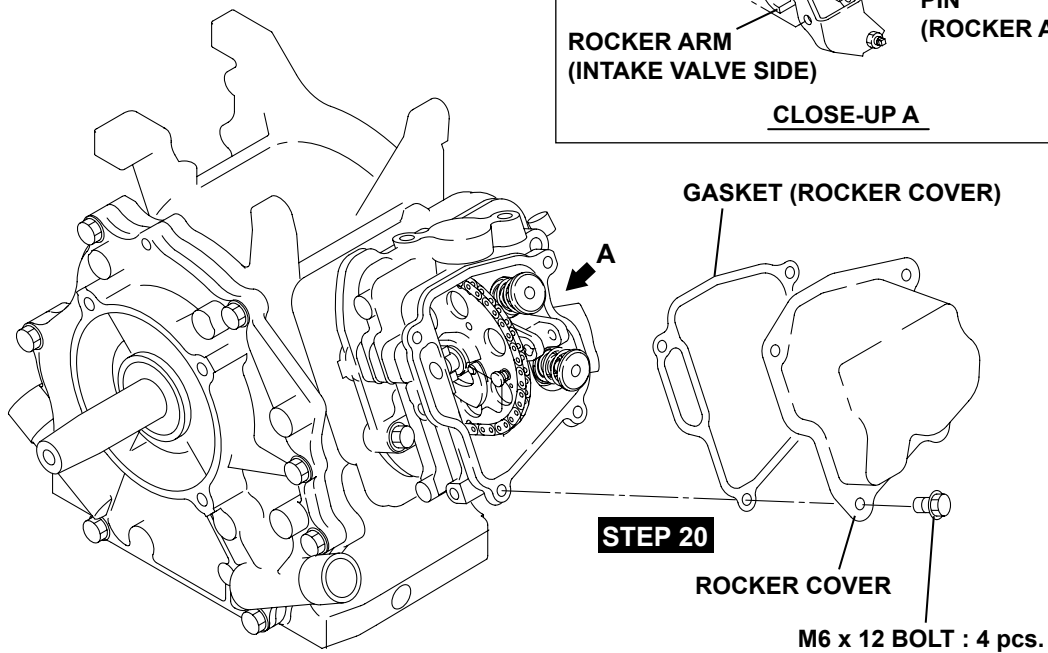
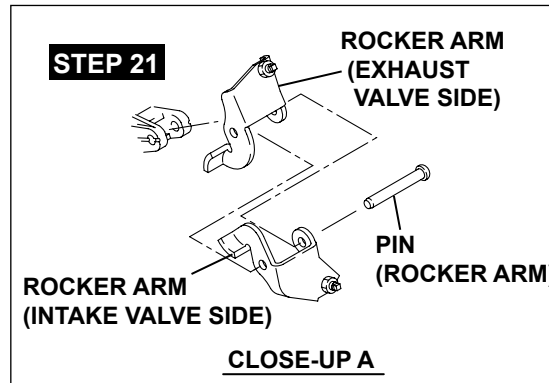
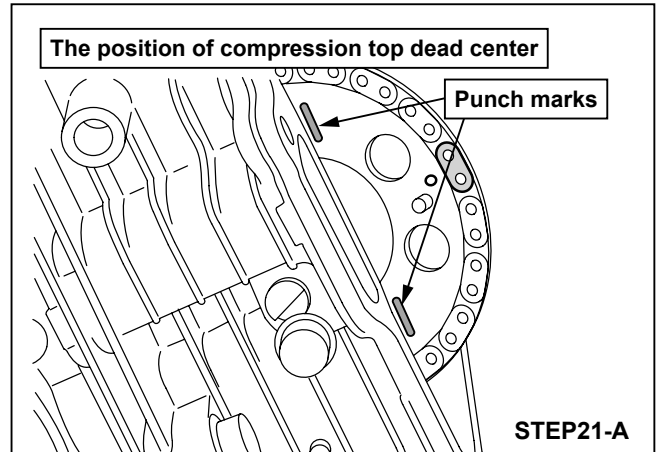
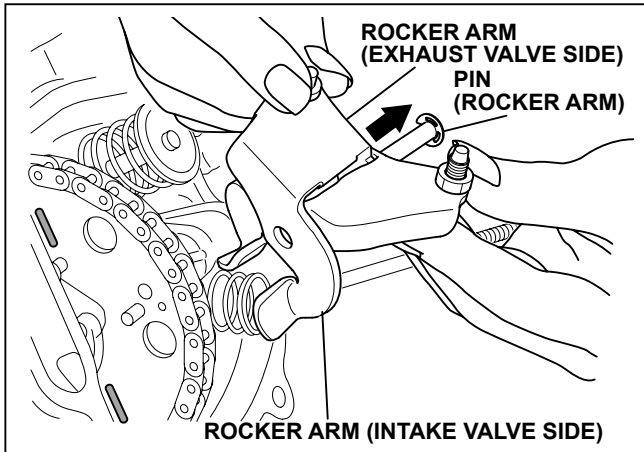

Step	Parts to remove	Remarks and procedures	Fasteners
22	Main bearing cover	Remove the flange bolts of main bearing cover from the crankcase. Remove the main bearing cover while tapping gently around the cover using a plastic hammer or similar tool. (See Figure STEP22-A) Be careful not to damage the oil gauge or oil seal or not to lose the pipe knocks.	12 mm box spanner M8 × 35mm : 7 pcs.

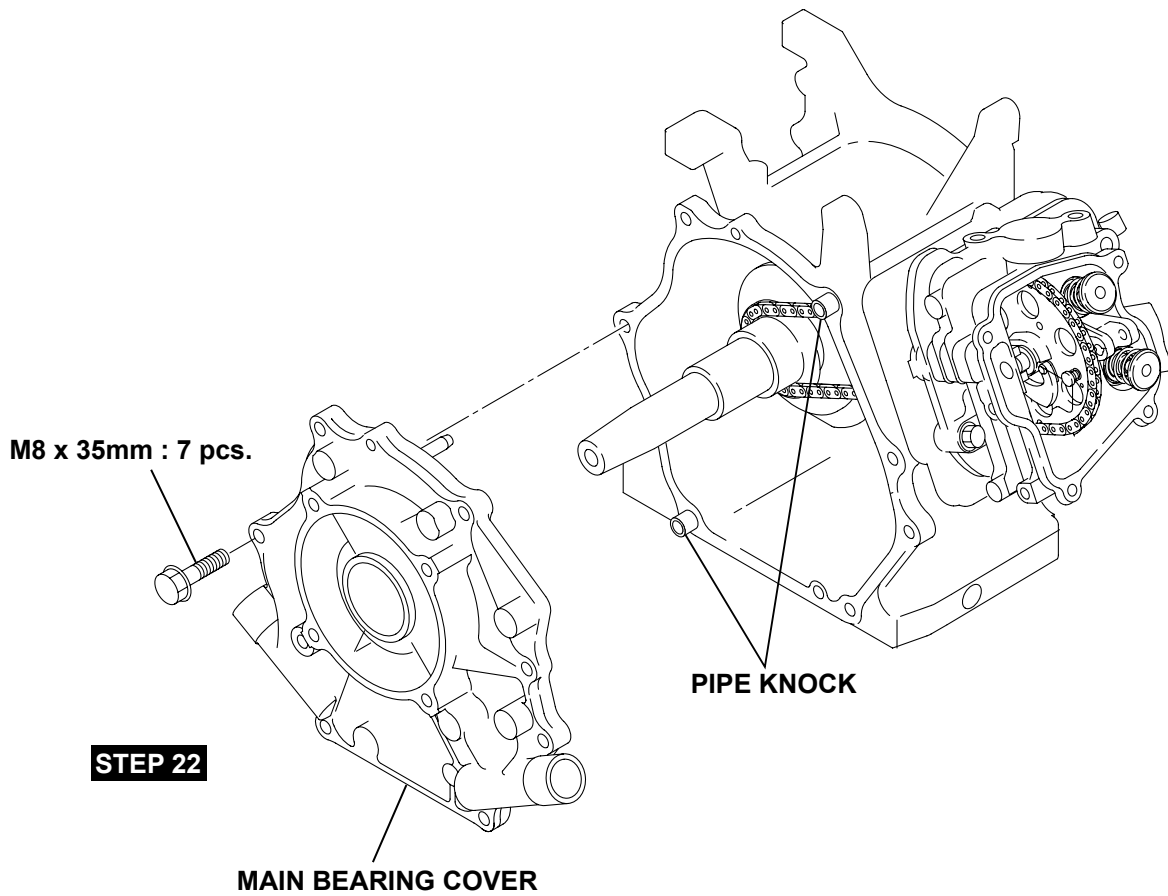
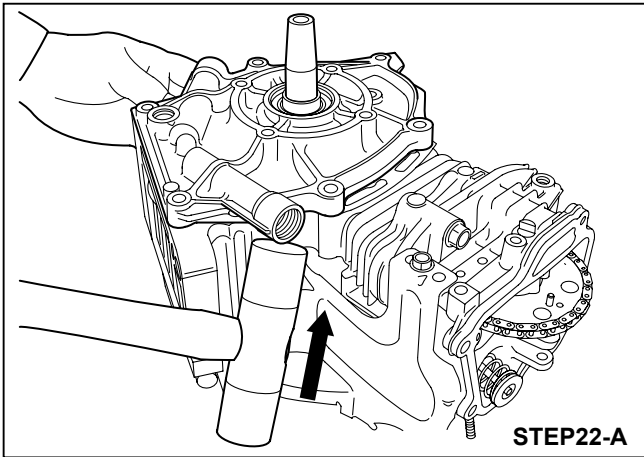

Step	Parts to remove	Remarks and procedures	Fasteners
23	Tensioner, Camshaft	(1) Remove the tensioner. (See Figure STEP23-A) Do not lose the pin (tensioner). (2) Remove the retaining bolt of pin (camshaft) from the cylinder head. (See Figure STEP23-B) (3) Remove the pin (camshaft), taking care not to scratch the O-ring. (4) Remove the chain from the camshaft sprocket and then take out the camshaft. (See Figure STEP23-C) (5) Remove the chain from the crankshaft.	M10 box spanner or spanner M6 × 12mm : 1 pc.

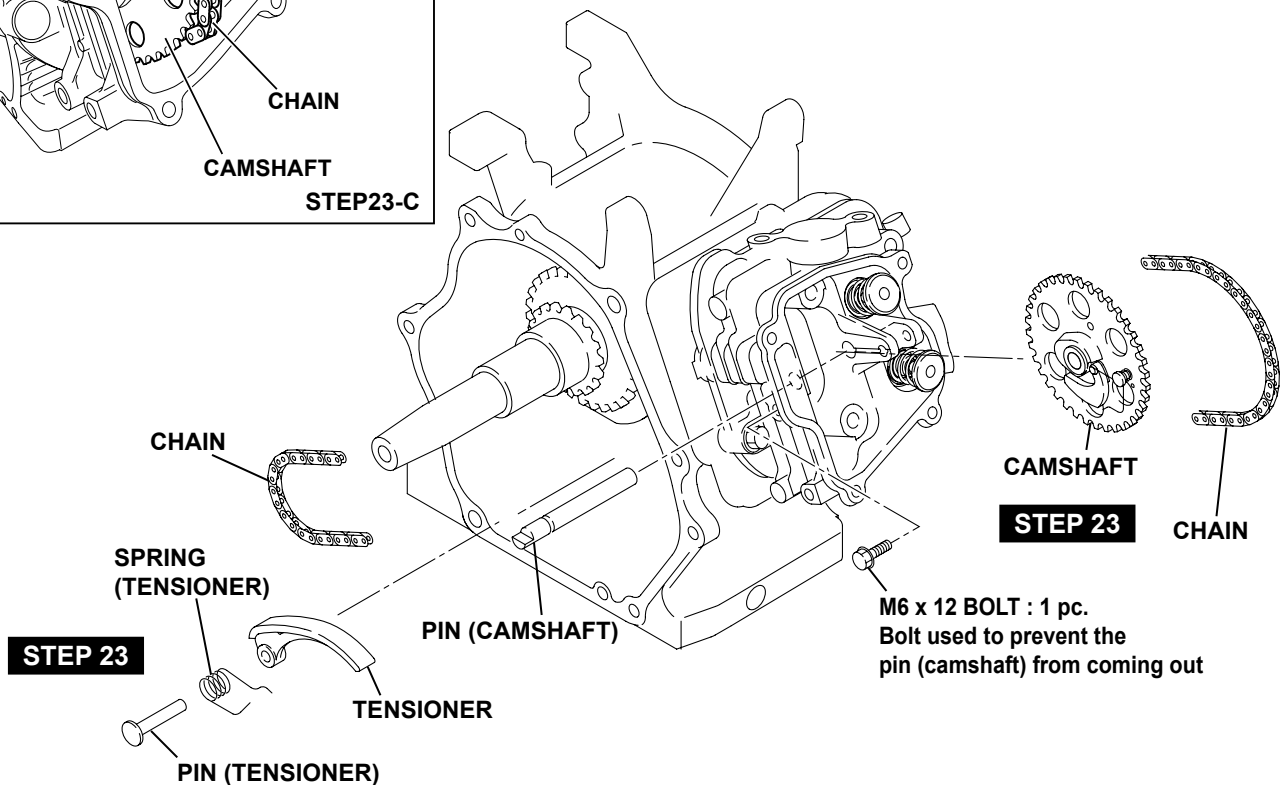
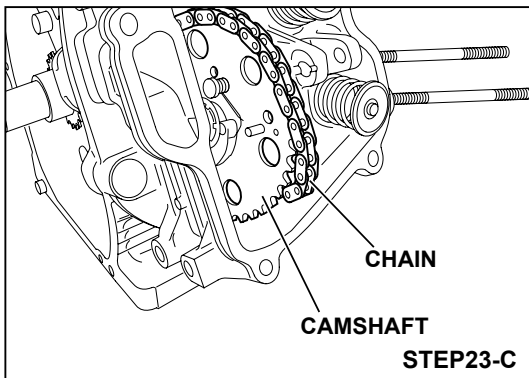
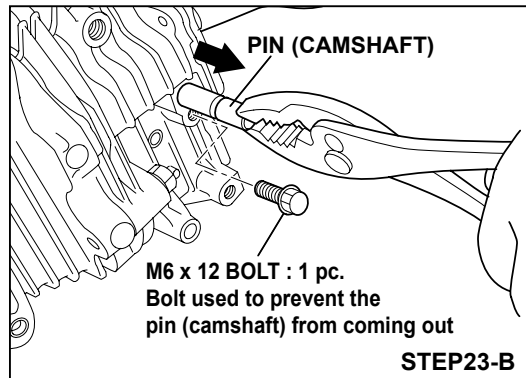
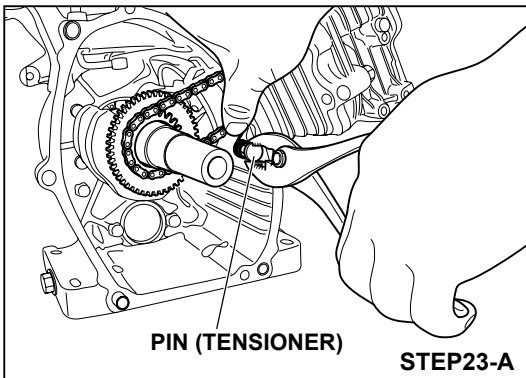

Step	Parts to remove	Remarks and procedures	Fasteners
24	Cylinder head, Chain guide	(1) Remove the cylinder head from the crankcase. (2) Remove the cylinder head gasket from the cylinder head. Take care not to lose the pipe knocks. (3) Remove the chain guide from the top side of the crankcase. (If the chain guide is removed from the inner side of the crankcase, it might be damaged.)	12 mm box spanner M8 × 68mm : 4 pcs. M8 × 33mm : 1 pc.
25	Intake and exhaust valves	(1) Remove the collet valve from the spring retainer. (See Figure STEP25-A) (2) Remove the intake valve and the exhaust valve.	

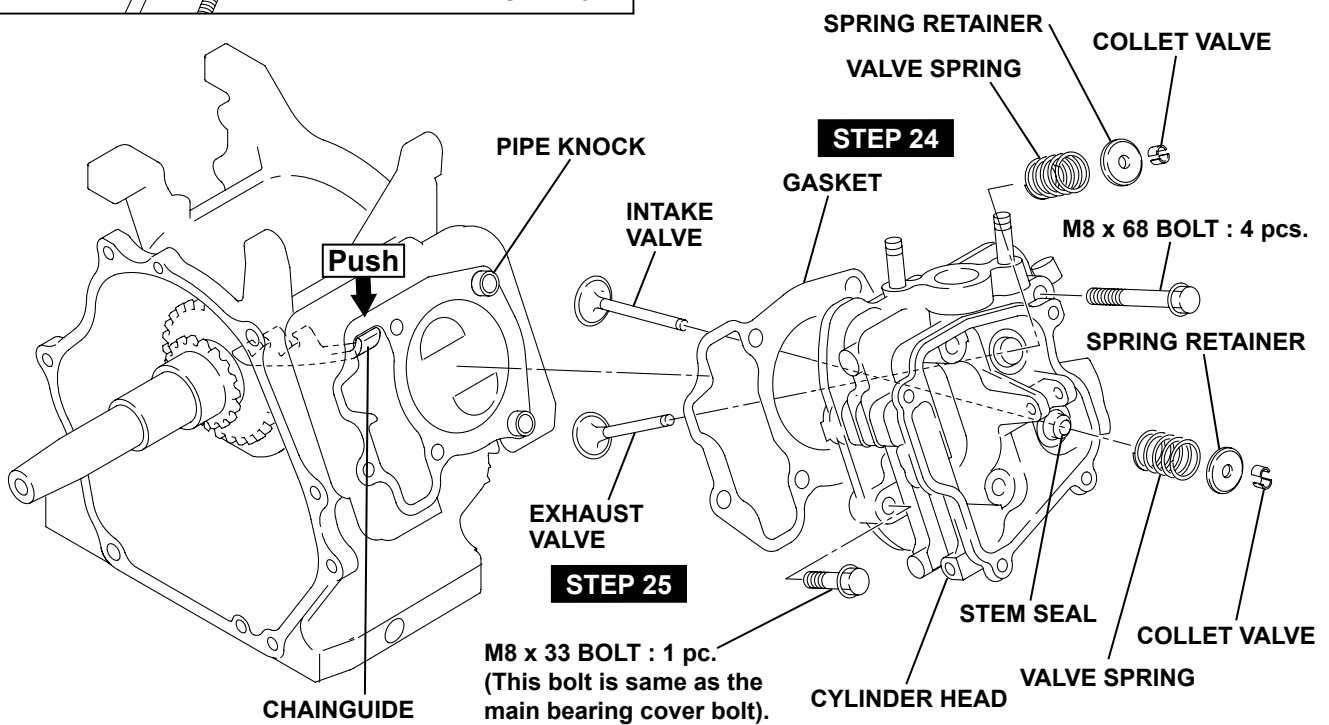
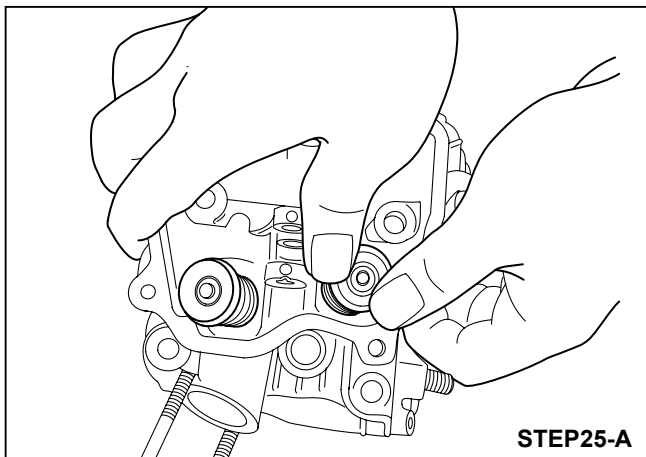

Step	Parts to remove	Remarks and procedures	Fasteners
26	Connecting rod and piston	(1) Scrape off any carbon from the cylinder and the piston head, then remove the connecting rod bolt. (2) Remove the connecting rod cap. (3) Rotate the crankshaft until the piston comes to its top position. Push the connecting rod and remove the piston from the upper part of the cylinder.	10 mm box spanner M7 × 40mm : 2 pcs.
27	Piston and piston rings	(1) Remove the piston clips (2 pcs.). Take out the piston pin and then remove the piston from the connecting rod small end, taking care not to damage the connecting rod small end. (2) Remove the piston rings from the piston by spreading them at the gap. Take special care not to damage the rings when doing this.	

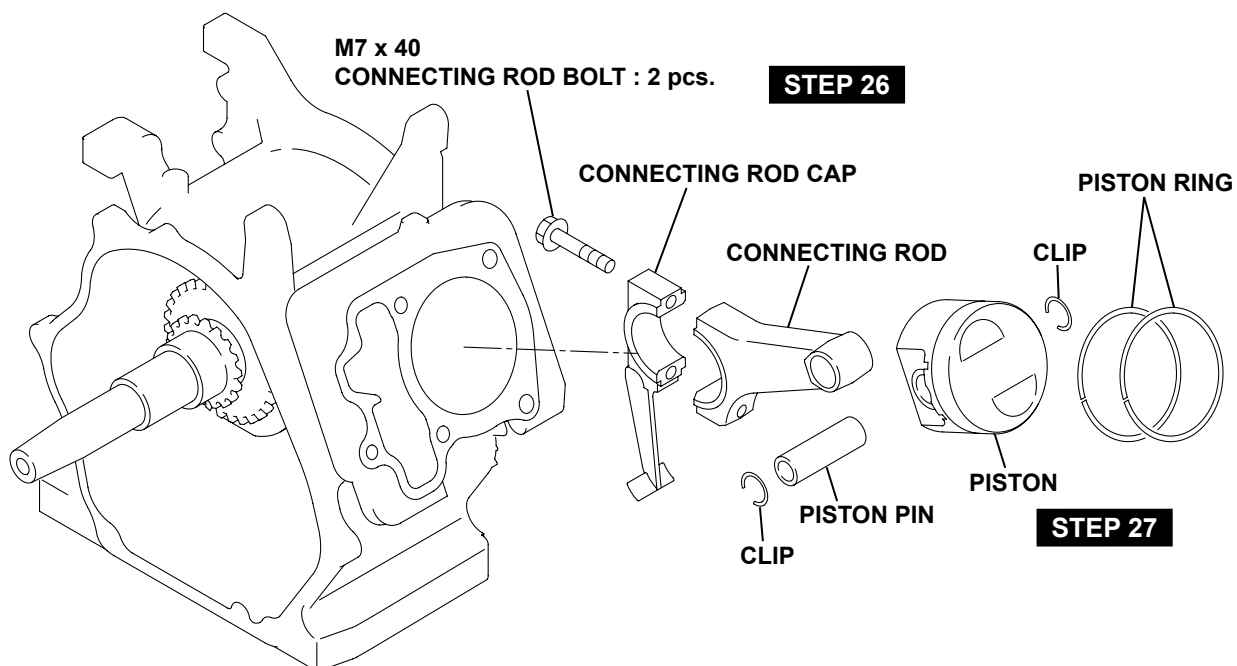

Step	Parts to remove	Remarks and procedures	Fasteners
28	Crankshaft	(1) Remove the woodruff key (for the flywheel magneto). (2) Remove the crankshaft from the crankcase by tapping its magneto side end with a plastic hammer, taking care not to damage the oil seal. (See Figure STEP28-A)	Plastic hammer
29	Oil sensor (option)	(1) Remove the clamp. (See Figure Step29-A) (2) Remove the oil sensor from the crankcase.	M6 × 12mm : 1 pc. M6 × 16mm : 2 pcs.

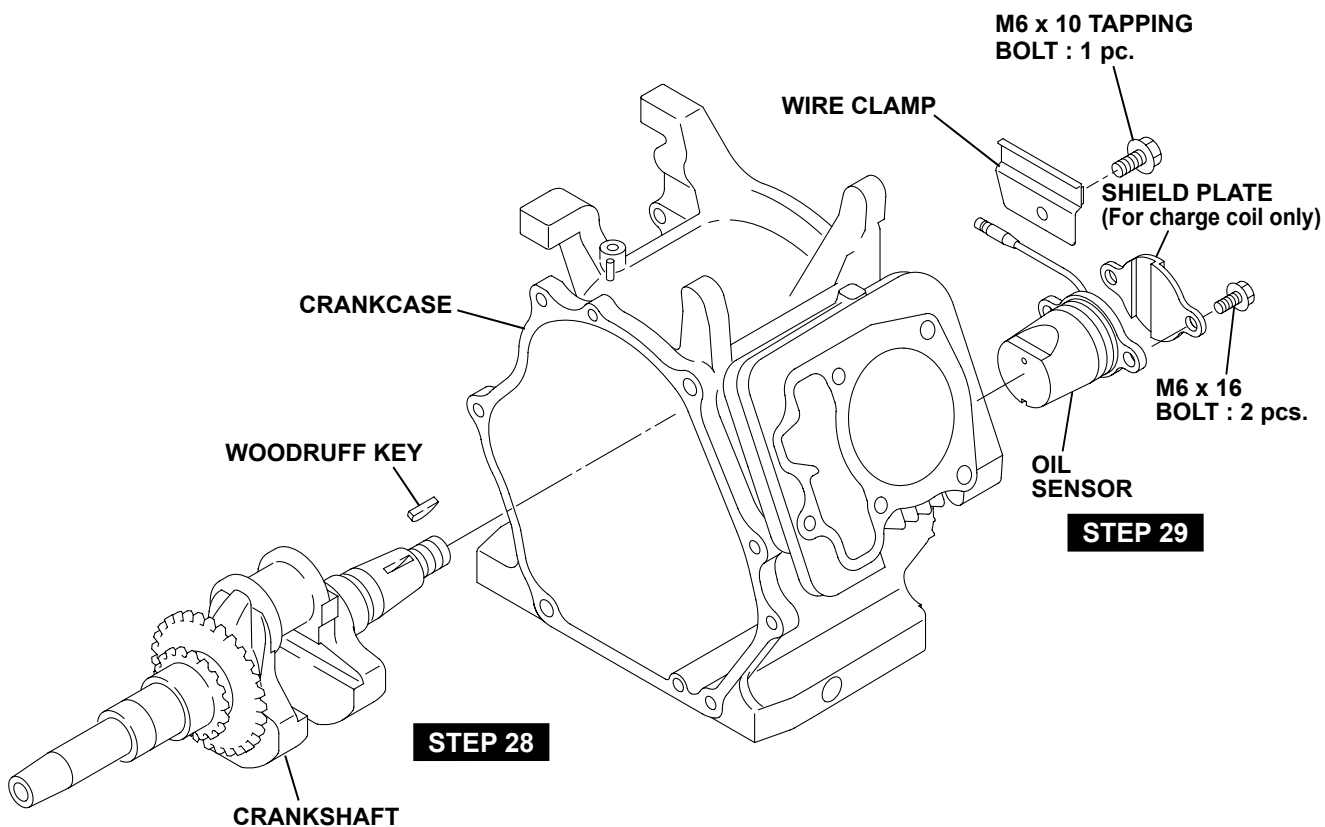
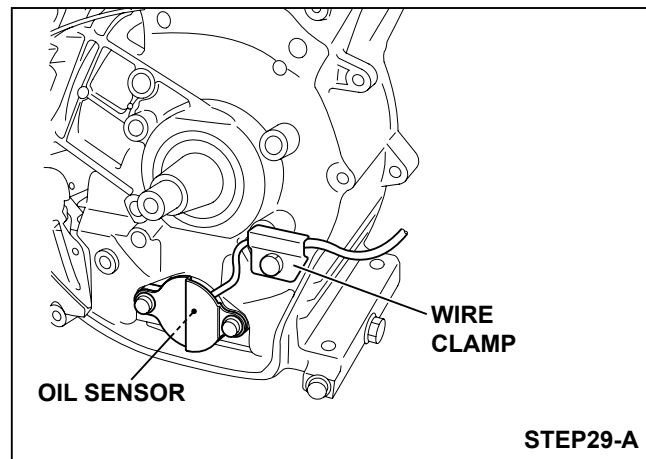
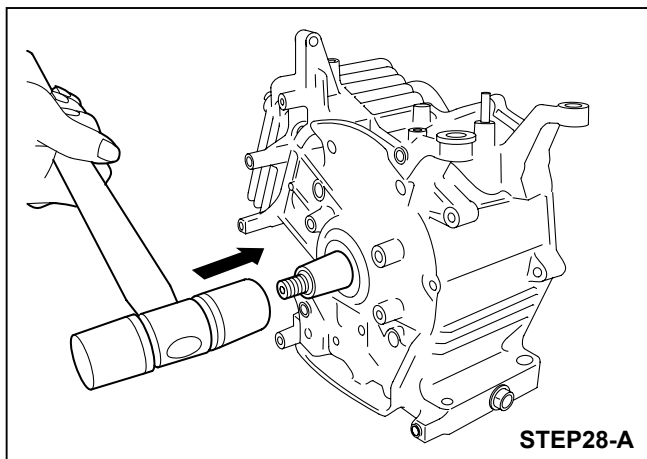

5-4 REASSEMBLY PROCEDURE

5-4-1 NOTES ON REASSEMBLY

- (1) Clean the each parts carefully, taking special care with the piston, cylinder, crankshaft, connecting rod and bearings.
- (2) Scrape off any carbon deposits on the cylinder head and the piston head. Be particularly careful when removing carbon from the piston ring grooves.
- (3) Inspect the oil seals for any damage to the lip. Replace them if damaged. Apply oil to the lip before reassembly.
- (4) Replace all the gaskets with new ones.
- (5) Replace the keys, pins, bolts and nuts with new ones, if necessary.
- (6) Tighten nuts and bolts to the specified torque settings.
- (7) When reassembling the engine, apply oil to all moving parts.
- (8) Check clearances and end plays and adjust, if necessary.
- (9) When mounting any major part during reassembly of the engine, rotate it with your hand to check for any jamming or abnormal noise.

5-4-2 ASSEMBLY STEPS AND PRECAUTIONS

(1) OIL SENSOR

- (a) Mount the oil sensor and fix the wire with the clamp.
- (b) Mount the shield plate only for charge coil type.

Tightening torque
10.0 N·m (100 kgf·cm) (7.2 ft·lb.)

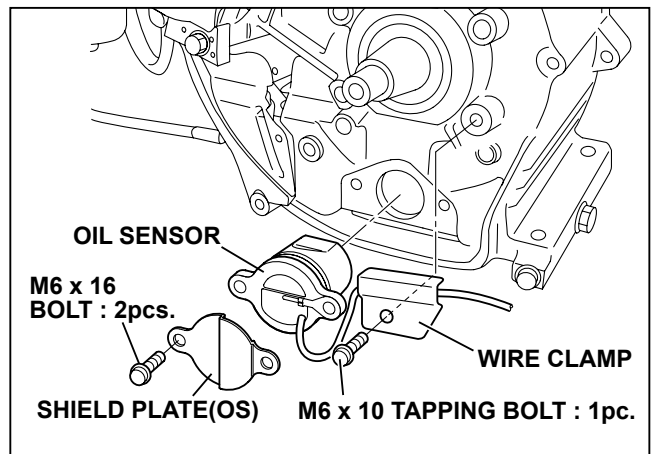

(2) CRANKSHAFT

- (a) Wrap the key-way portion of the crankshaft with polyvinyl tape and insert the crankshaft into the crankcase, taking care not to damage the oil seal lip.
- (b) Insert the woodruff key (for the flywheel magneto).

NOTE: Do not insert the woodruff key before inserting the crankshaft into the crankcase.

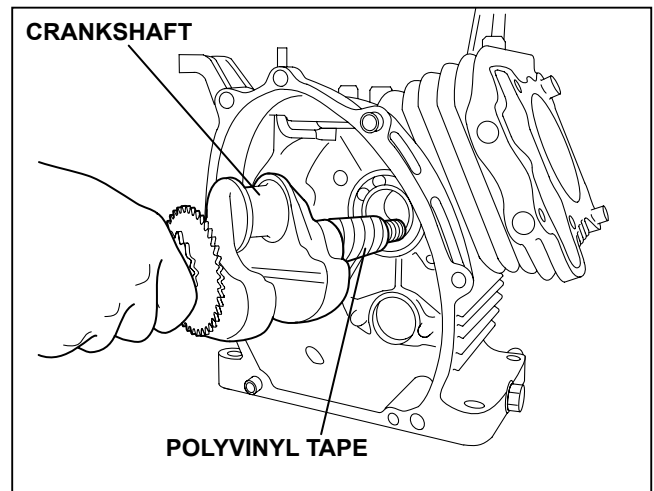

(3) PISTON AND PISTON RINGS

Install each piston ring in the correct groove of the piston by widening it enough to slide it over the piston.

NOTE: Be careful not to twist the rings too much, as they may be damaged. Install the oil ring first, followed by the top ring. When installing the piston ring, make sure that the "N" mark is face up.

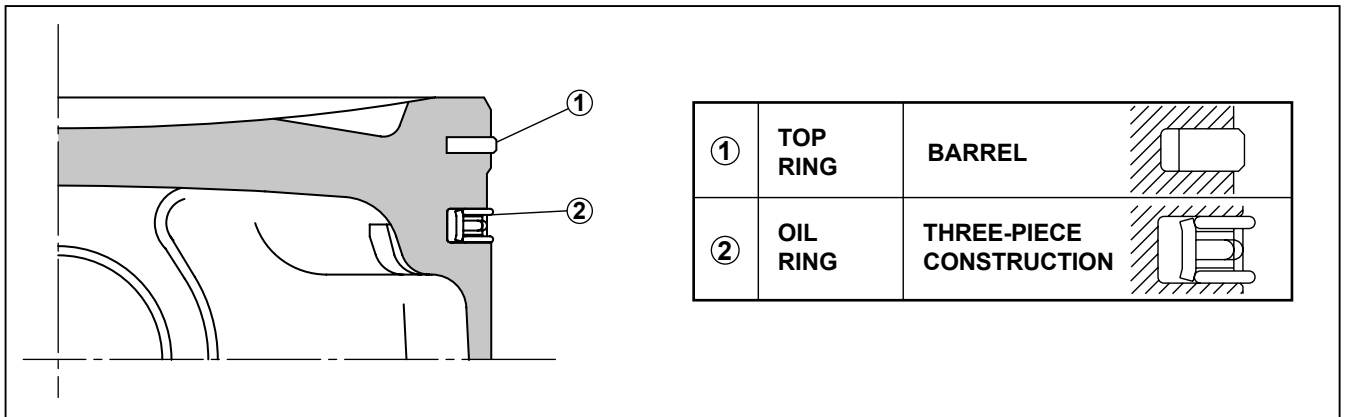
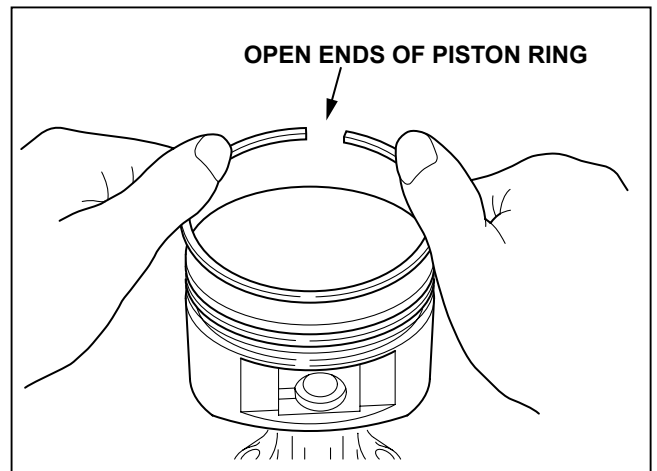
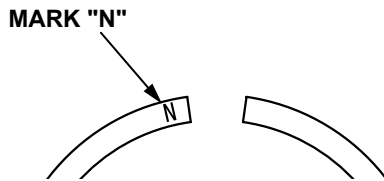

(4) PISTON AND CONNECTING ROD

The piston is attached to the connecting rod by the piston pin.

When assembling the piston and connecting rod, make sure to align the mark on the piston head with the "MAG" mark on the connecting rod.

NOTE1: Before assembling the connecting rod, apply oil to its small end.

NOTE2: Be sure to insert the clips in the two ends of the piston pin and check the clips for any play.

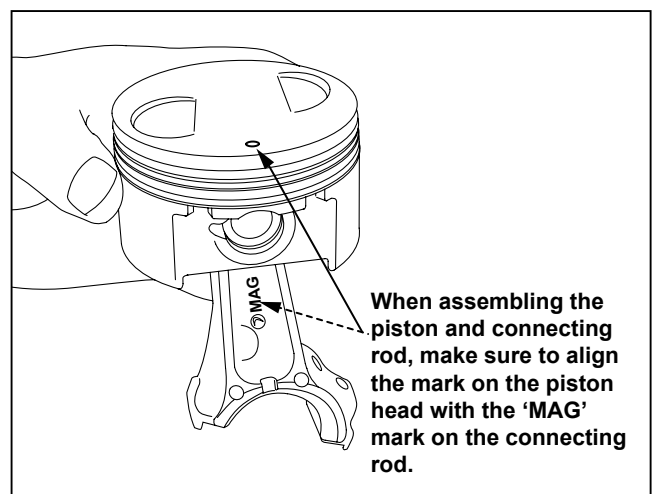

(5) CONNECTING ROD

- (a) Install the piston and connecting rod assembly into the cylinder by holding the piston rings with the ring guide, with the "MAG" mark on the connecting rod on the flywheel side. (If you do not have a ring guide, hold the piston rings with the fingers and tap the upper part of the piston with a piece of wood.)

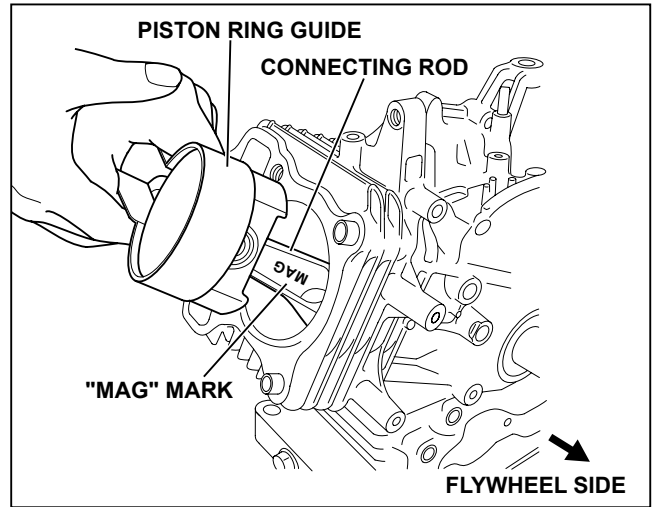

NOTE1: Apply oil to the piston rings, the large end of the connecting rod and cylinder before installing the connecting rod into the cylinder.

NOTE2: The piston ring gaps should be positioned around the piston at 90-degree intervals.

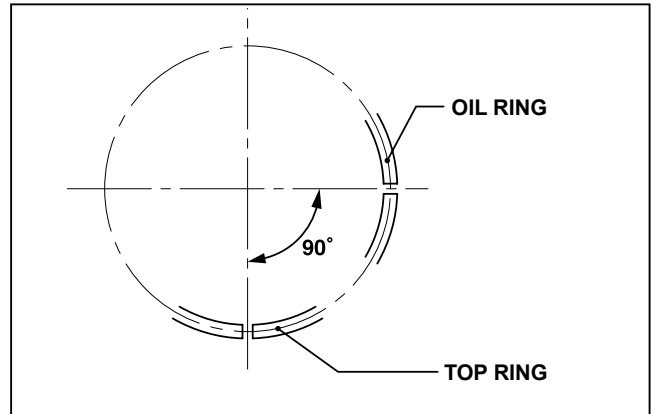

- (b) Rotate the crankshaft down to the bottom dead center and lightly tap the piston head until the large end of the connecting rod touches the crank pin.

- (c) To mount the connecting rod, line up the matching marks and fit the clinch portions firmly together.

Tightening torque
17.0 - 20.0 N·m (170 - 200 kgf·cm) (12.3 - 14.5 ft·lb.)

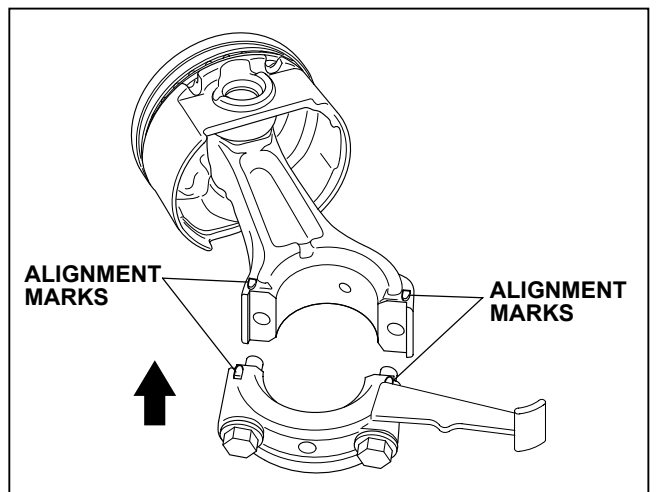

- (d) Check for free movement of the connecting rod by turning the crankshaft slowly.

(6) INTAKE AND EXHAUST VALVES

Take the following points into account when mounting the intake and exhaust valves on the cylinder head.

NOTE1: Replace the valve with a new one if it shows signs of wear. (Refer to the "STANDARD REPAIR TABLES" on page 71 and 72.)

NOTE2: Carefully scrape off any carbon deposits on the combustion chamber. Apply oil to the valve stems before mounting the intake and exhaust valves. Insert the valves in the cylinder head and place it on a level workbench. Next, mount the valve springs, the spring retainers and collet valves. (Mount the stem seal on the intake valve guide.)

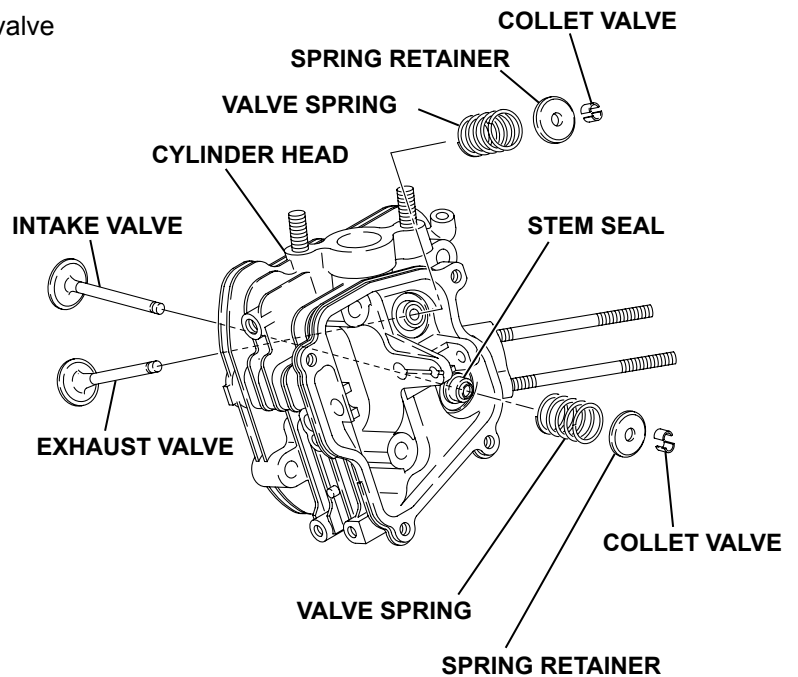
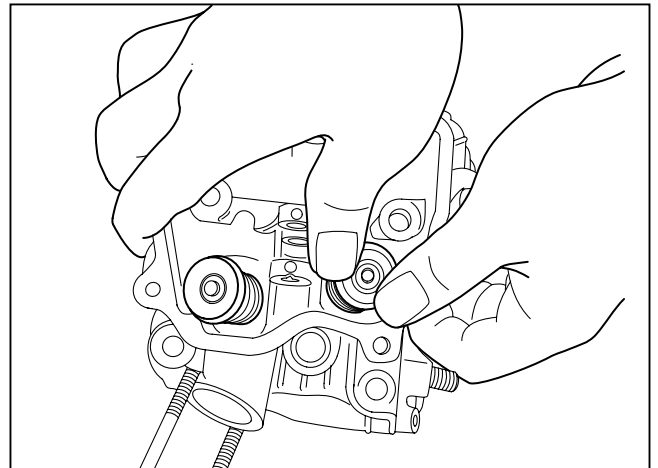

(7) CHAIN GUIDE

Mount the chain guide to the crankcase.

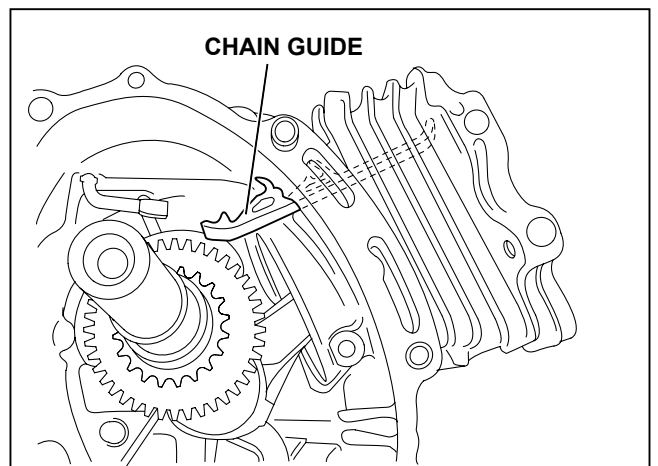
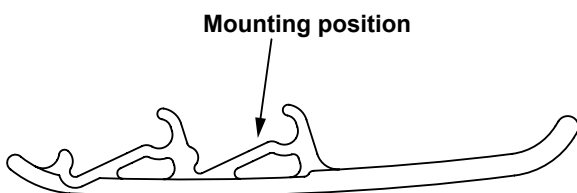

(8) CYLINDER HEAD

Inspect and repair any scratches on mounting surface and replace head gasket to new one before installing.

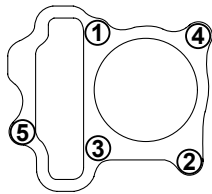
Cylinder head bolts	Tightening Torque		Remarks
	1st STEP	2nd STEP	
M8 × 68mm flange bolt : 4 pcs.	 17.0 - 19.0 N•m (170 - 190 kgf•cm) (12.3 - 13.7 ft•lb.)	25.0 - 27.0 N•m (250 - 270 kgf•cm) (18.1 - 19.5 ft•lb.)	Re-use
M8 × 33mm flange bolt : 1 pcs.		28.0 - 30.0 N•m (280 - 300 kgf•cm) (20.3 - 21.7 ft•lb.)	—

Tighten the cylinder head bolts in diagonal order.

(1) Re-use (Oil the screw thread)

- Tighten all bolts (5pcs) by 18 ± 1 N•m primary, and then tighten longer ones (M8 × 68mm flange bolt: 4pcs) by 26 ± 1 N•m.

(2) When replace to new cylinder head and flange bolts (Oil the screw thread)

- Tighten all bolts (5pcs) by 18 ± 1 N•m primary, and then tighten longer ones (M8 × 68mm flange bolt: 4pcs) by 29 ± 1 N•m.

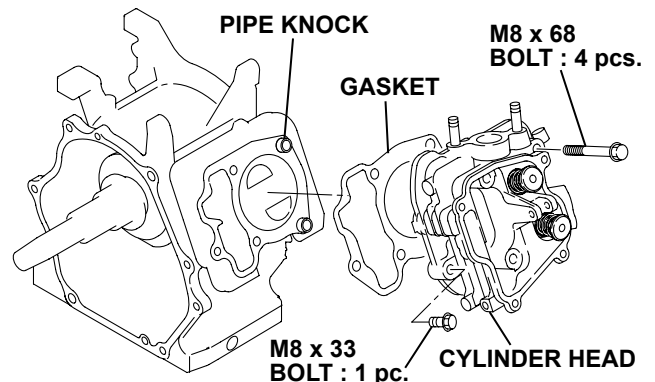

(9) SETTING THE TIMING CHAIN

(a) Align the timing mark on the crankshaft sprocket with the mark plate of the timing chain.

(b) Align the timing mark on the crankshaft sprocket with the mark plate of the opposite end of the timing chain.

Number of oval steel link : 100

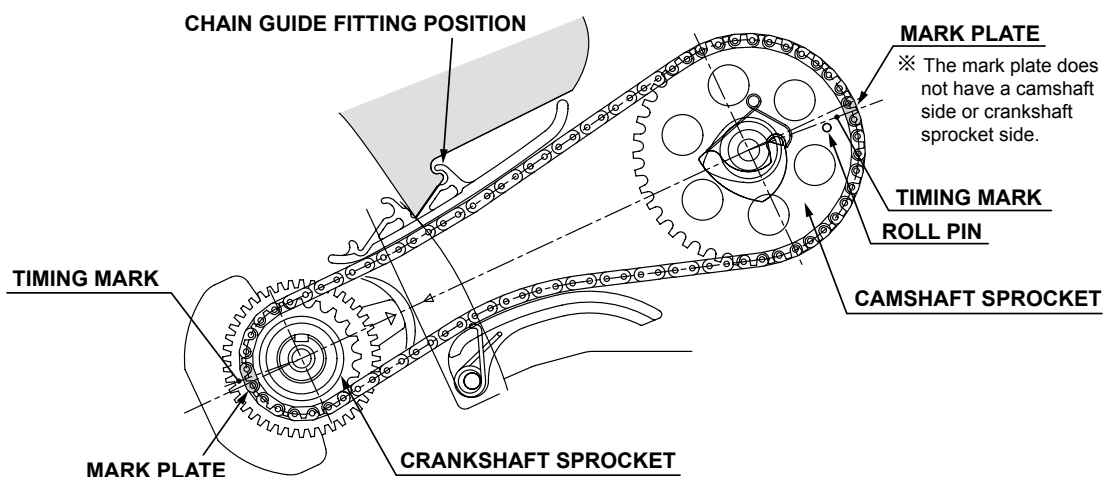

(10) MOUNTING THE CAMSHAFT ON THE CYLINDER HEAD

Mount the camshaft on the cylinder head by inserting the pin (camshaft) through the head.
 Fix the bolt to prevent the pin (camshaft) from coming out.

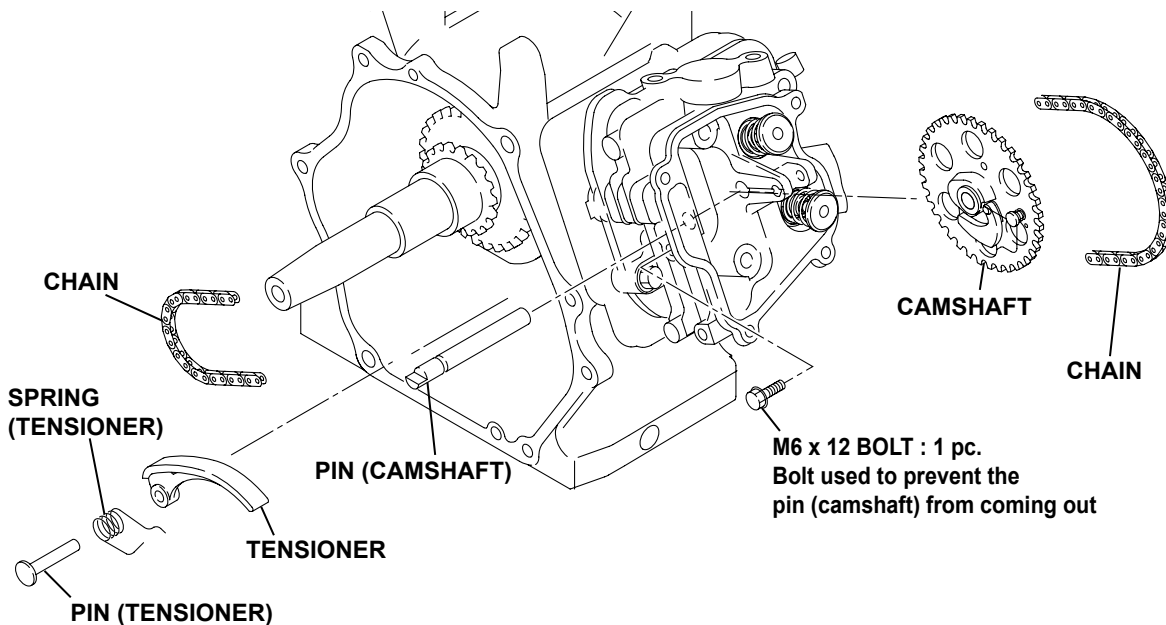
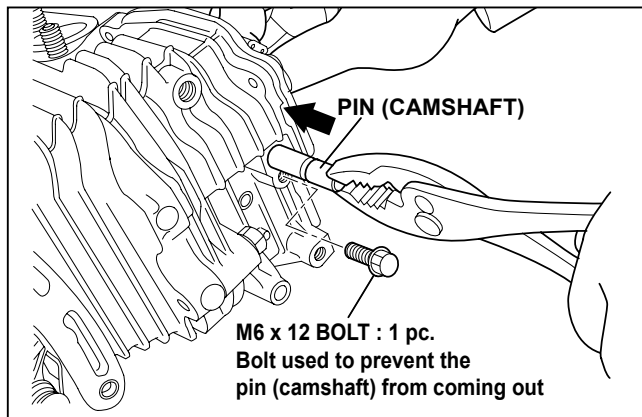
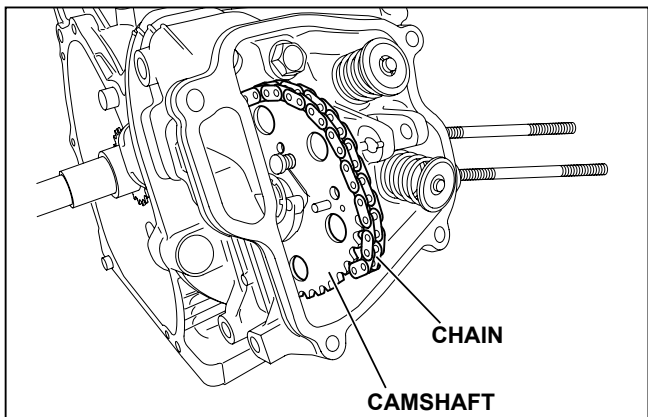

(11) MOUNTING THE TENSIONER

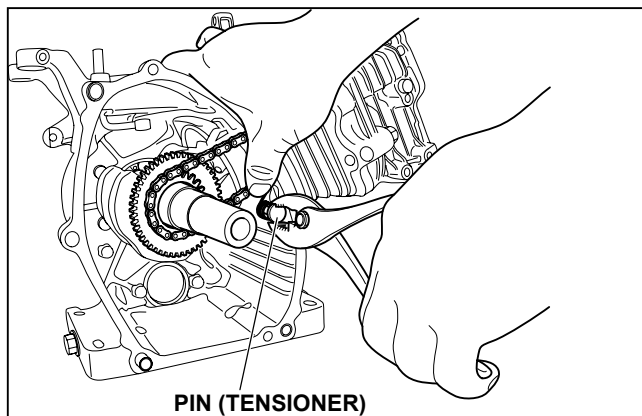
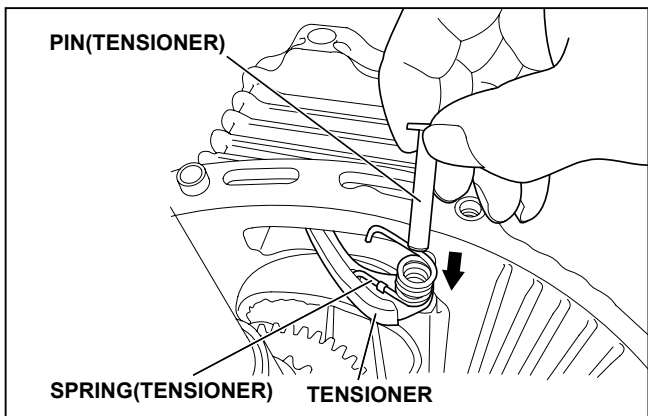

(12) MAIN BEARING COVER

Apply oil to the bearing and the oil seal lip when mounting the main bearing cover. Also apply sealant (Three Bond "1215" to the surface of the crankcase. To avoid damaging the oil seal lip, wrap the crankshaft key-way portion with polyvinyl tape before mounting the main bearing cover.

NOTE: Be careful that the lever portion of governor shaft does not face the main bearing cover.

Tightening torque
17.0 - 18.0 N·m (170 - 180 kgf·cm) (12.3 - 13.0 ft·lb.)

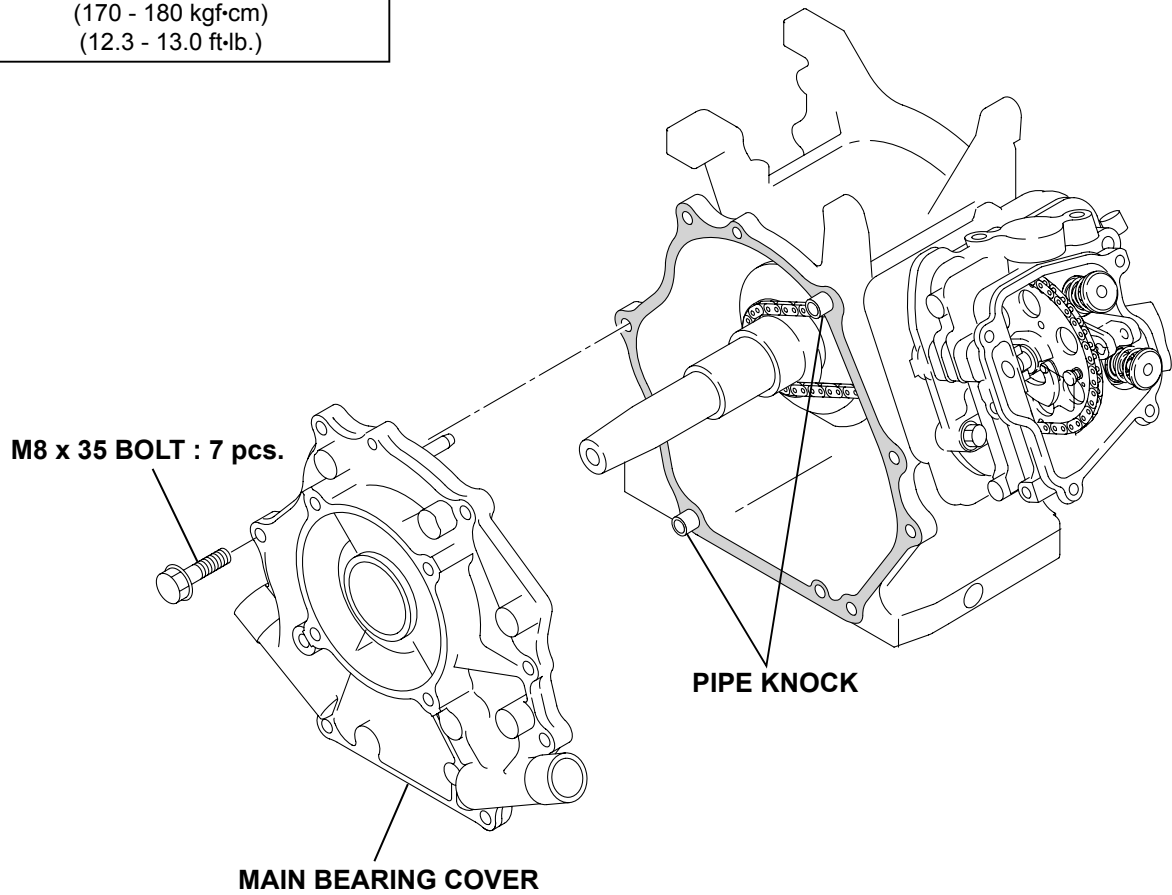

(13) Pass the pin (rocker arm) through the rocker arm and mount them on the cylinder head.

NOTE1: Conduct this job at the compression top dead center.
 (The position of two punch marks on cam sprocket is in parallel with the cylinder head surface at a time.)

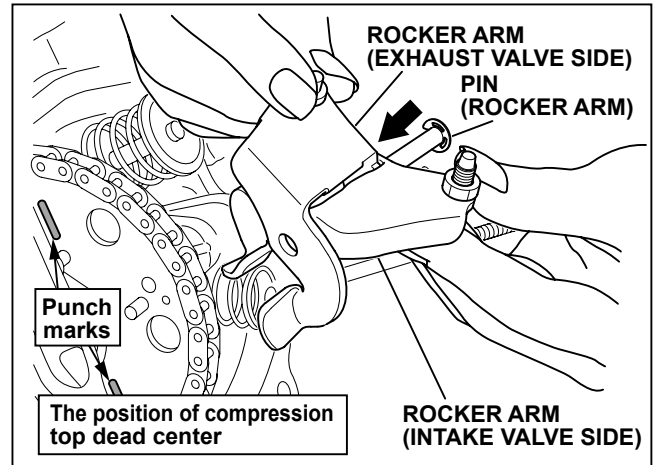

NOTE2: Make sure that the piston is at the compression top dead center by checking mutual position between the flywheel and the ignition coil.

(14) VALVE CLEARANCE ADJUSTMENT

Temporarily fit the flywheel.
 Rotate the crankshaft up to the compression top dead center and insert the thickness gauge between the valve and the adjusting screw of rocker arm to measure the clearance.

[Adjustment method]

Loosen the nut on the adjustment screw and turn the screw to adjust the valve clearance. When the valve clearance is correct, tighten the nut.

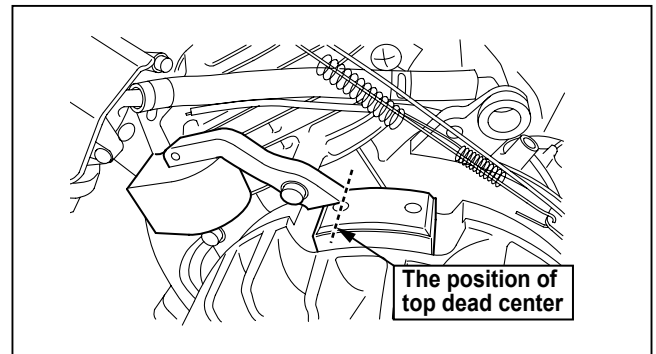

Valve clearance (when the engine is cold)	
Intake valve side	0.12 ^{+0.03} / ₀ mm
Exhaust valve side	(0.0047 ^{+0.0012} / ₀ in.)

Tightening torque
5.0 - 7.0 N•m (50 - 70 kgf•cm) (3.6 - 5.1 ft•lb.)

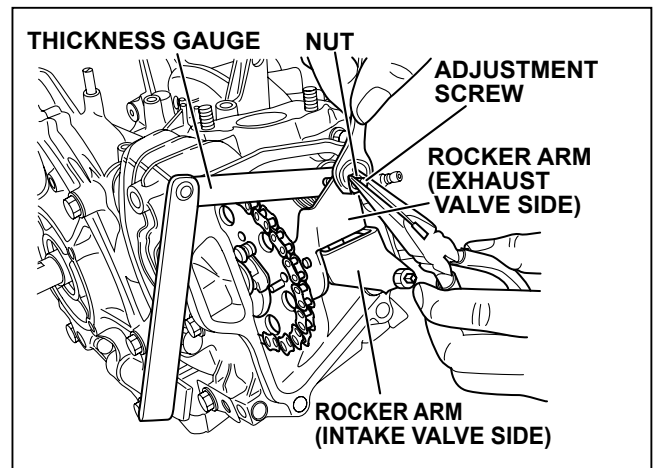

NOTE: After adjusting the valve clearances, rotate the crankshaft and check again that the intake and exhaust valve clearance are correct.

(15) ROCKER COVER

Replace the gasket with a new one, and mount the rocker cover.

M6 × 12mm flange bolt : 4 pcs.

Tightening torque
5.0 - 7.0 N·m (50 - 70 kgf·cm) (3.6 - 5.1 ft·lb.)

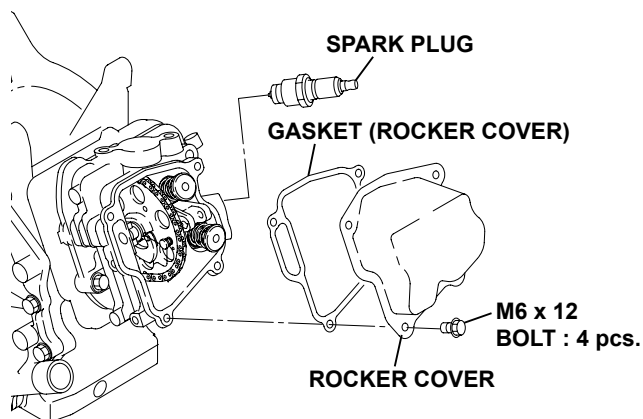

(16) SPARK PLUG

Remove any carbon deposits from the spark plug and inspect the electrode for damage before mounting. Replace with a new one, if necessary.

Spark plug: NGK BR-6HS

Electrode gap	0.6 mm - 0.7 mm

Tightening torque	
New spark plug	Re-tightening torque
12.0 - 15.0 N·m (120 - 150 kgf·cm) (8.7 - 10.8 ft·lb.)	23.0 - 27.0 N·m (230 - 270 kgf·cm) (16.6 - 19.5 ft·lb.)

(17) BAFFLE 1 (CASE)

Align the top and bottom of the baffle 1 (case) with the crankcase and mount it with the bolts.

[Model without electric starter]

M8 × 12 mm bolt : 1 pc.

[Model with electric starter]

Mount the electric starter and the charging coil, referring to the illustrations of disassembly.

Tightening torque
12.0 N·m (120 kgf·cm) (8.7 ft·lb.)

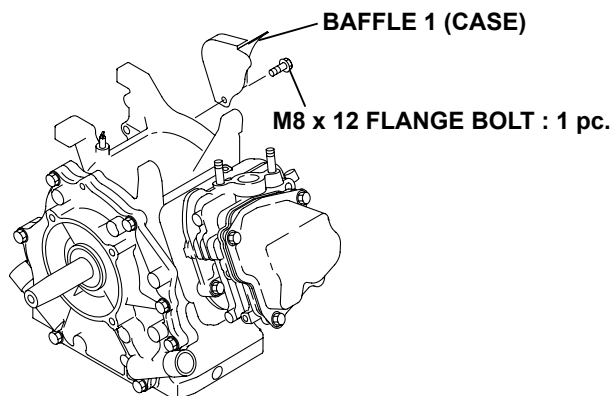

(18) FLYWHEEL AND STARTING PULLEY

NOTE1: Wear work gloves during operation to avoid a possible injury by a sharp edge.
 NOTE2: When mounting the flywheel, be sure to wipe off any oil on the tapered portion of the crankshaft and flywheel.

Mount the flywheel on the crankshaft.
 (Tighten the flywheel together with the starting pulley.)

Tightening torque	
59.0 - 64.0 N•m (590 - 640 kgf•cm) (42.7 - 46.3 ft•lb.)	

M8 nut : 1 pc.

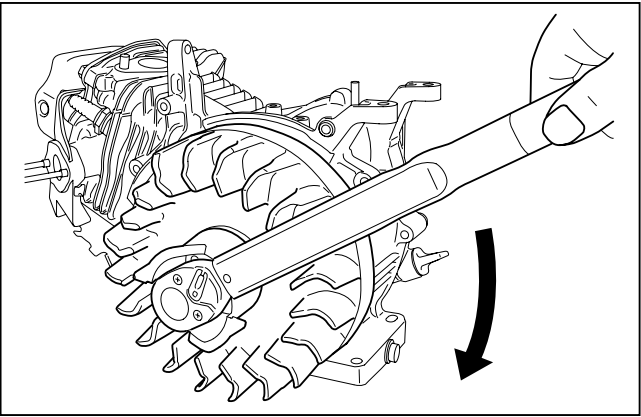
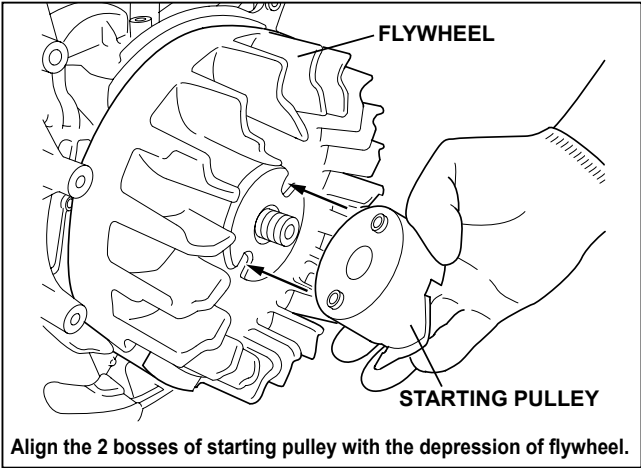

(19) IGNITION COIL

When mounting the ignition coil, insert a thickness gauge between the ignition coil and the flywheel to check the air gap.

Air gap	0.3 mm - 0.5 mm
---------	-----------------

Tightening torque	
7.0 - 9.0 N•m (70 - 90 kgf•cm) (5.1 - 6.5 ft•lb.)	

M6 × 25 bolt and washer : 2 pcs.

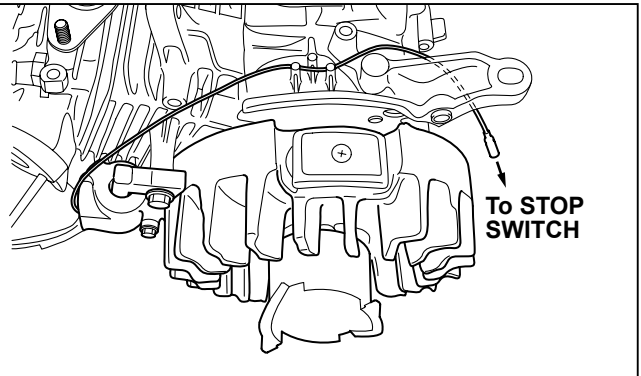
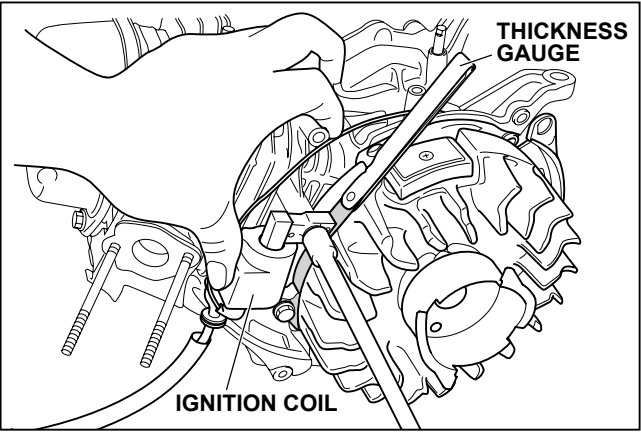

(20) SPEED CONTROL LEVER, BRACKET AND BAFFLE

Mount the speed control lever and bracket, baffle 2 (head) on the crankcase.

(21) CARBURETOR

- (a) Replace the gasket of insulator with a new one and mount the insulator on the cylinder head intake side.
- (b) Align the cord of ignition coil with the cut-out in the insulator to fit the carburetor.

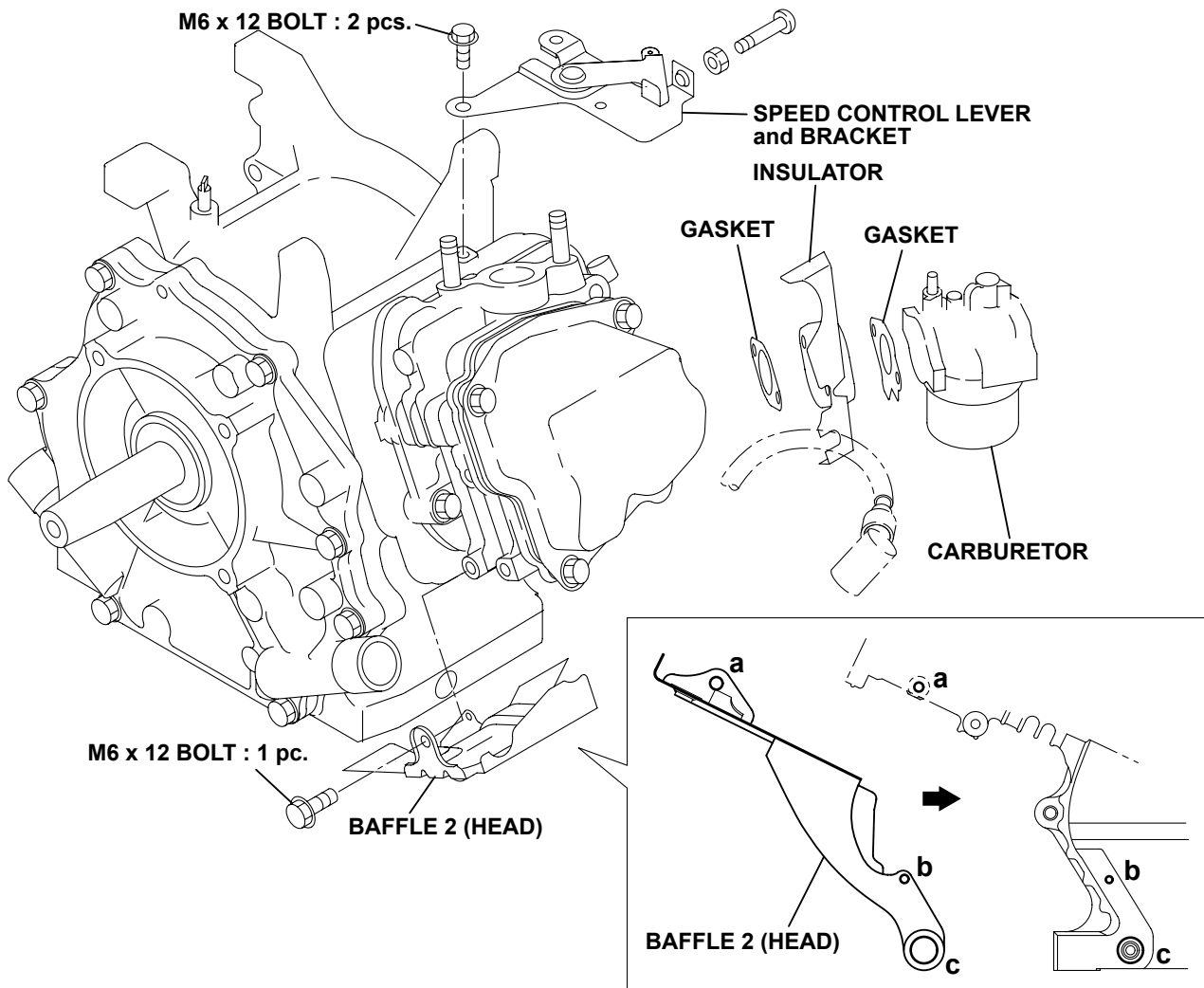

(22) GOVERNOR LEVER

- (a) Pass the governor rod through the rod spring, then connect to the throttle lever of the carburetor.
- (b) Attach the governor rod and rod spring to the governor lever, then mount the governor lever on the governor shaft. Do not adjust the bolt on the governor lever yet.
- (c) Connect the governor lever and the speed control lever with the governor spring.

NOTE: See page 38 for details on the adjustment method after mounting air cleaner base.

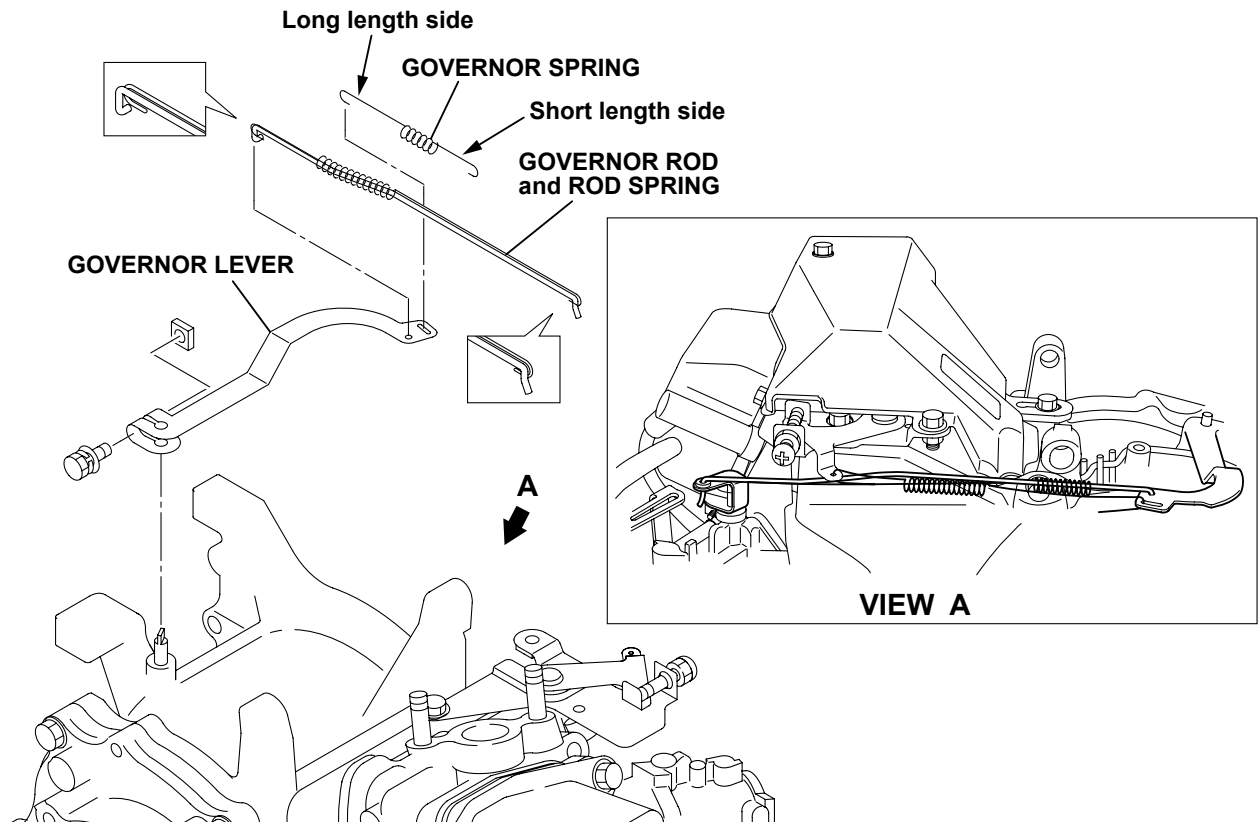

(23) EXHAUST PIPE and DUCT(CASE)

Mount the Exhaust pipe and the gasket on the cylinder head.

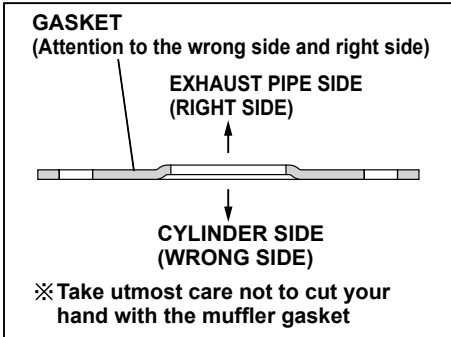

M8 flange bolt : 3 pcs.

Tightening torque
18.0 - 22.0 N·m (180 - 220 kgf·cm) (13.0 - 15.9 ft·lb.)

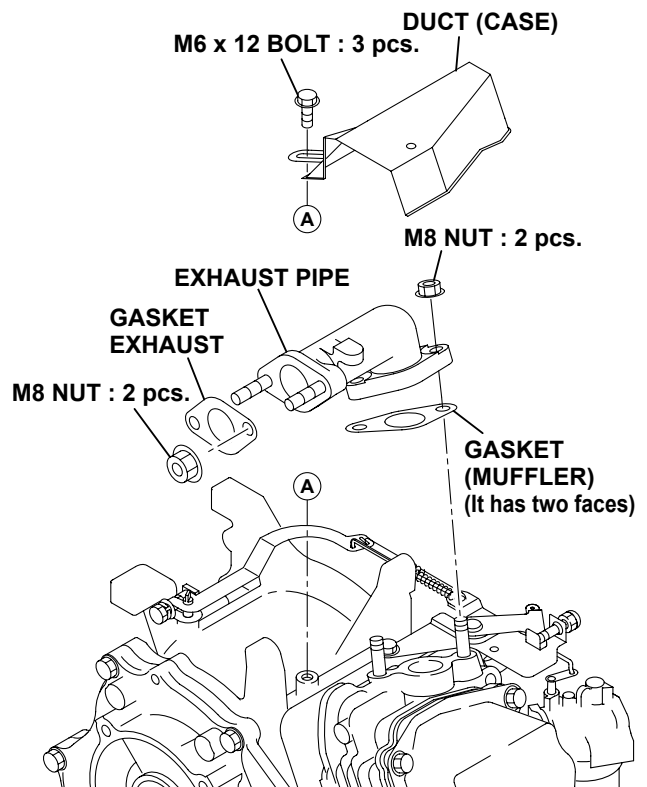

(24) BLOWER HOUSING AND RECOIL STARTER

(a) Align the cord of ignition coil with the cut-out with that of the blower housing to mount the blower housing on the crankcase.

M6×14 mm bolt : 4 pcs.

(b) Mount the recoil starter on the blower housing.

M6×14 mm bolt & washer : 4 pcs.

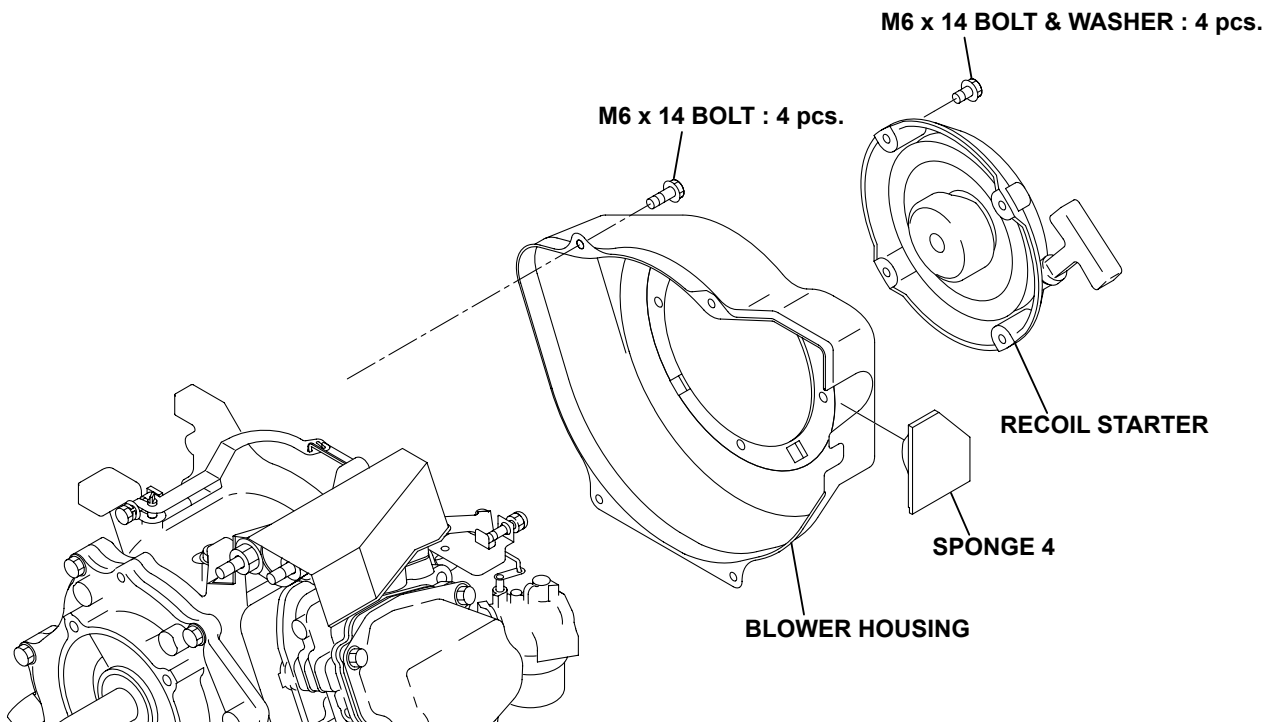

(25) AIR CLEANER BASE

Insert the breather pipe into the rocker cover and then mount the air cleaner base.

M6 flange nut : 2 pcs.

Tightening torque
6.0 - 8.0 N•m (60 - 80 kgf•cm) (4.3 - 5.8 ft•lb.)

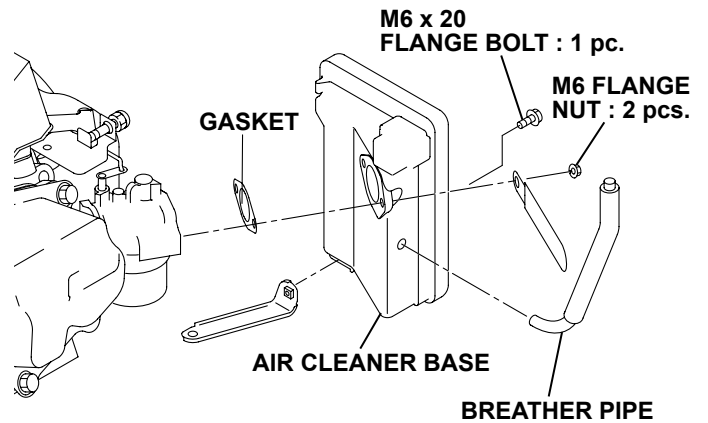

■ Governor system adjustment method

The governor unit is a centrifugal flyweight type and is installed on the governor gear.

Since it automatically adjusts the throttle valve of the carburetor by means of a link mechanism, it is possible to maintain a constant engine speed, even with load variations.

- (1) Turn the speed control lever to the full speed position, making sure that the carburetor throttle valve is fully open.
- (2) Hold the top of the governor shaft with the plier and turning it clockwise as far as it will go. Tighten the bolt on the governor lever.

Tightening torque
8.0 - 10.0 N•m (80 - 100 kgf•cm) (5.8 - 7.2 ft•lb.)

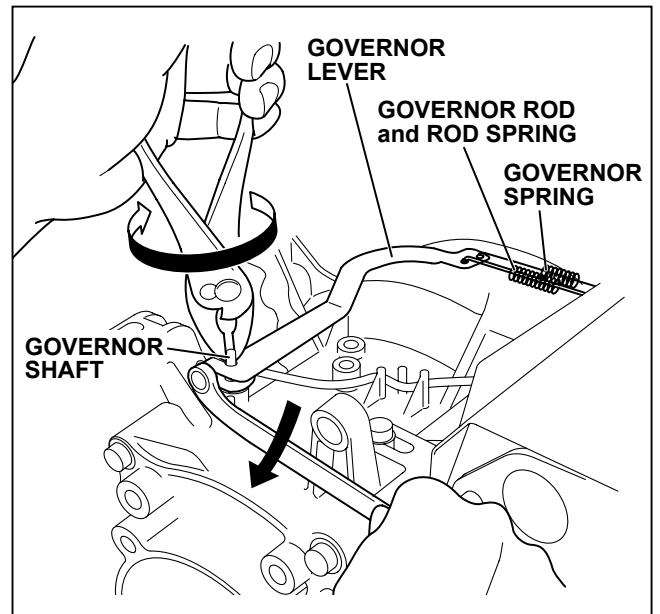

(26) STOP SWITCH (FLOAT C/U CP5)

- (a) Mount the stop switch on the blower housing.
- (b) Refer to the wiring diagram (See page 45 and 46) for wiring details.

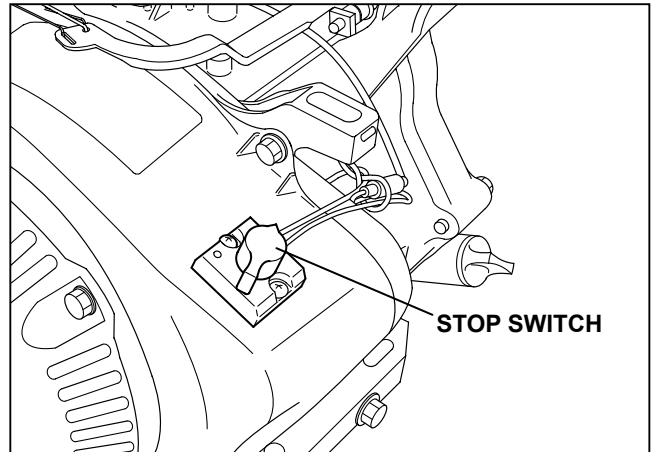

(27) AIR CLEANER

Mount the air cleaner element and cleaner cover.

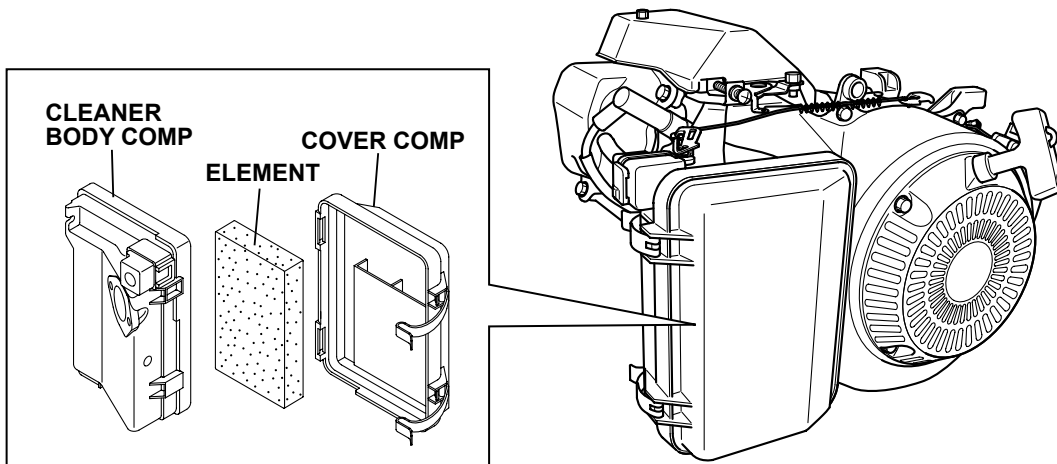

(28) EXTERNAL INSPECTION

Reassembly is completed. Check that the wiring is correct and that there are no loose nuts and bolts or any other faults visible on the outside of the engine.

(29) FILLING WITH ENGINE OIL

Use the automobile engine oil of API service class SE or higher grade.

The amount of oil depends on the engine model. Refer to the table below.

Engine oil volume	1.0 L
-------------------	-------

(30) BREAK-IN OPERATION

A new engine or an engine that has been completely overhauled by being fitted with a new piston, rings, valves and connecting rod should be thoroughly RUN-IN before being put back into service.

Good bearing surfaces and running clearances between the various parts can only be established by operating the engine under reduced speed and loads for a short period of time.

While the engine is being tested, check for oil leaks.

Make final carburetor adjustment and regulate the engine operating speed.

Step	Load	Engine speed	Time
Step 1	No Load	2500 r.p.m.	10 min.
Step 2	No Load	3000 r.p.m.	10 min.
Step 3	No Load	3600 r.p.m.	10 min.
Step 4	3.5 HP	3600 r.p.m.	30 min.
Step 5	7 HP	3600 r.p.m.	30 min.

6. ENGINE OIL

Using engine oil of the correct grade and viscosity greatly lengthens engine life and improves performance. Too much or too little oil can also result in serious problems, including engine seizure.

6-1 CLASSIFICATION BY OIL GRADE

API (American Petroleum Institute)

Classification	SA	SB	SC	SD	SE	SF	SG	SH	SJ
----------------	----	----	----	----	----	----	----	----	----



Grades suited for Robin Engine: SE or higher (SG,SH or SJ in recommended)

6-2 CLASSIFICATION BY OIL VISCOSITY

SAE (Society of Automotive Engineers)

Single grade	5W	10W	20W	#20	#30	#40	
Multigrade	10W-30						
	10W-40						
Ambient temperature	-20	-10	0	10	20	30	40°C
	-4	14	32	50	68	86	104°F

Be sure to use automobile engine oil of the viscosity shown in the table above, depending on environmental air temperature.

When the air temperature falls below -20°C or rises above 40°C, be sure to choose engine oil of appropriate viscosity and grade, according to the prevailing conditions.

※ Care must be taken when using multi-grade engine oil, because the oil consumption rate tends to increase when the air temperature is high.

6-3 ADDING AND CHANGING ENGINE OIL

- Engine oil inspection and filling up Every time you use the engine
(add engine oil up to the designated maximum level)
- Engine oil change First time After 20 hours' use
Thereafter Every 100 hours' use

7. MAGNETO

7-1 MAGNETO

The Robin Engine uses a T.I.C. type breakerless magneto ignition system.

(1) T.I.C. (TRANSISTOR IGNITER CIRCUIT) has the ignition coil outside the flywheel, which is the standard specification. A charge coil system is available as an option.

(The flywheel is a specialized piece of equipment.)

As for the lighting coil, the ignition coil is outside the flywheel and a lighting coil is inside.

7-2 INSPECTING THE MAGNETO

If the engine does not start, has difficulty starting, or does not run smoothly, check the magneto for defects according to the following procedure:

(1) Carefully check the high-tension cable for any damage or short circuiting.

(2) Check the sparking.

① Take the spark plug out of the cylinder head, connect the spark plug with the plug cap and ground it on the cylinder head or any other metallic part of the engine.

(The gap between the electrodes of the spark plug should be between 0.6 mm and 0.7 mm).

② Rotate the engine by pulling the recoil starter and check the spark plug gap for sparking. If the spark plug is sparking, check the intensity of the spark.

(Before checking the spark plug, disconnect the primary wire from the connector.)

③ Next, disconnect the spark plug from the plug cap and check the end of the high-tension cable for sparking.

7-3 IGNITION SYSTEM

7-3-1 IGNITION COIL INTERNAL CIRCUIT

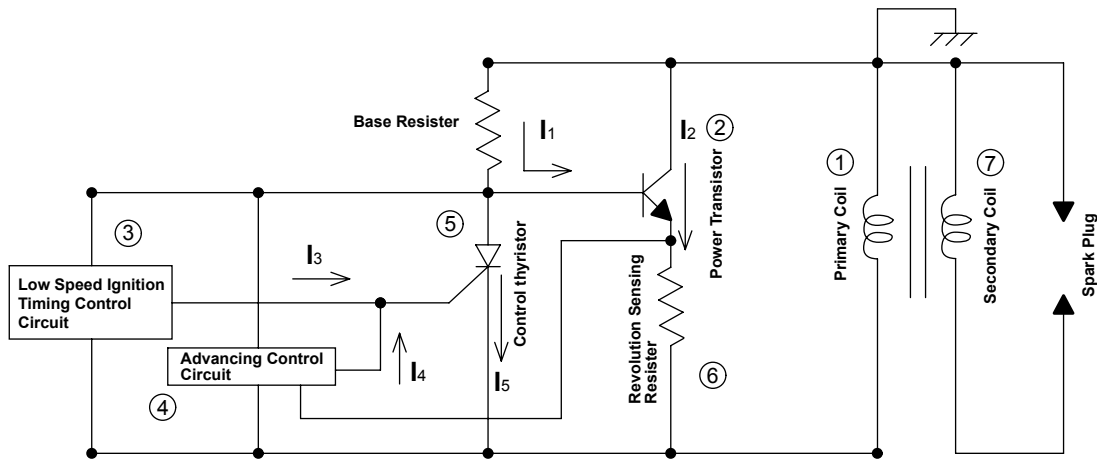

7-3-2 IGNITION TIMING CHARACTERISTIC

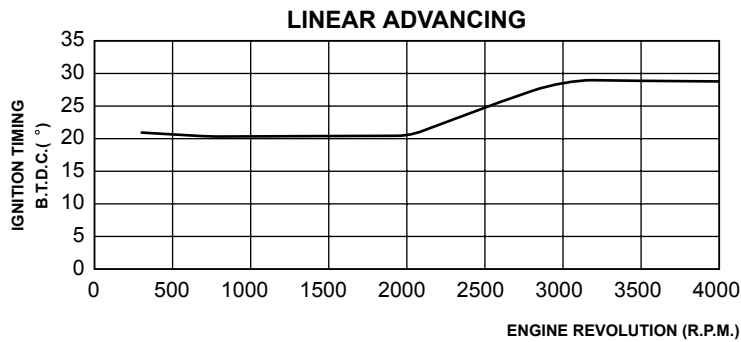

7-3-3 BASIC THEORY

- (a) Revolution of the flywheel generates electricity on the primary side of the ignition coil (①), and the base current I_1 flows to the power transistor (②). Current I_1 turns the power transistor "ON" and the electric current I_2 flows. This is the same situation when the contact breaker is closed in a case of breaker point type ignition system.
- (b) At lower engine revolution, the low speed ignition timing control circuit (③) operates to run the gate current I_3 to turn the control thyristor (⑤) "ON" thus the current I_1 bypass the thyristor as current I_5 . At this moment, the power transistor (②) turns "OFF" and the current I_2 is shut off abruptly resulting in the high voltage generated in the secondary coil (⑦) which produces sparks at the spark plug. The ignition timing at lower engine revolution is less advanced as shown in the above chart.
- (c) At higher engine revolution (over 2,000rpm), advancing control circuit (④) operates to run the gate current I_4 to turn the control thyristor (⑤) "ON", thus the current I_1 bypass the thyristor as current I_5 . At this moment, the power transistor (②) turns "OFF" and the current I_2 is shut off abruptly resulting in the high voltage generated in the secondary coil (⑦) which produces sparks at the spark plug. At over 2,000rpm, ignition timing on each engine revolution is controlled by advancing control circuit (④) that receive electrical information from revolution sensing resistor (⑥). The advancing of ignition timing from lower to higher engine revolution changes lineally as shown in the above chart.

8. WIRING DIAGRAM

8-1 MODEL WITHOUT ELECTRIC STARTER

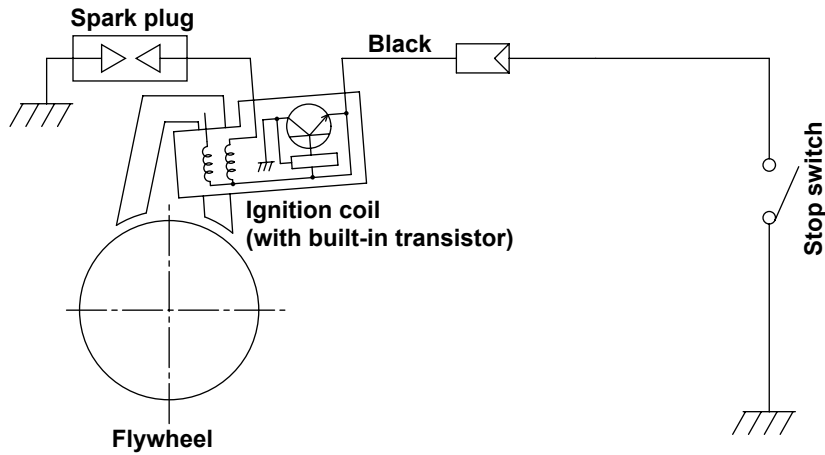

8-2 MODEL WITH ELECTRIC STARTER

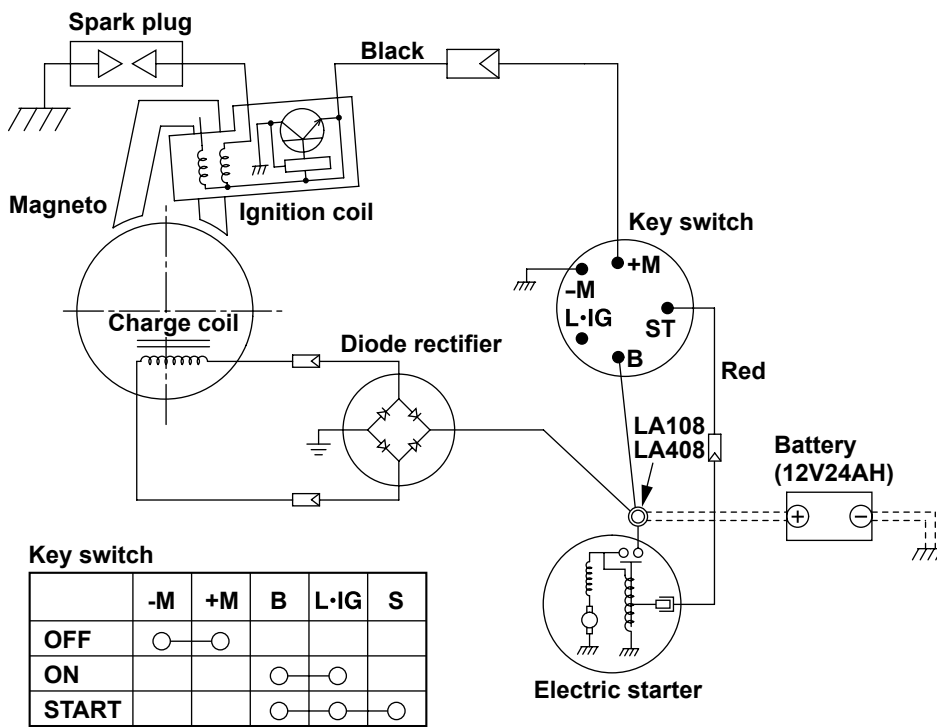

8-3 MODEL WITH OIL SENSOR

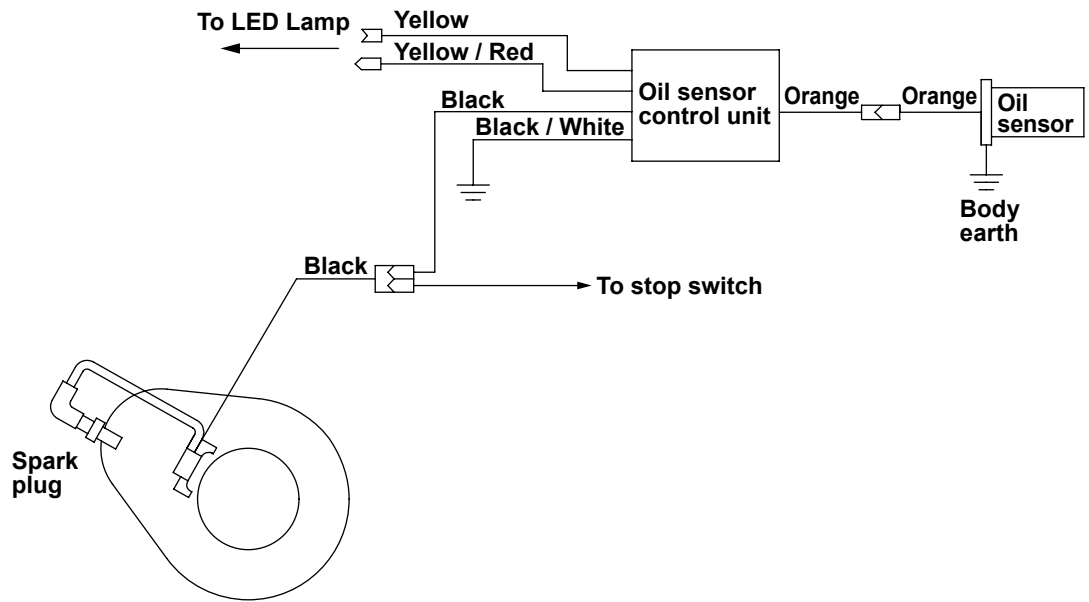

10. OIL SENSOR

10-1 SPECIFICATIONS

Type	Float type (with lead switch incorporated)
Resistance (at FULL oil level)	100 M ohms or over
Operating Temperature	-30 to +180 degree Celsius

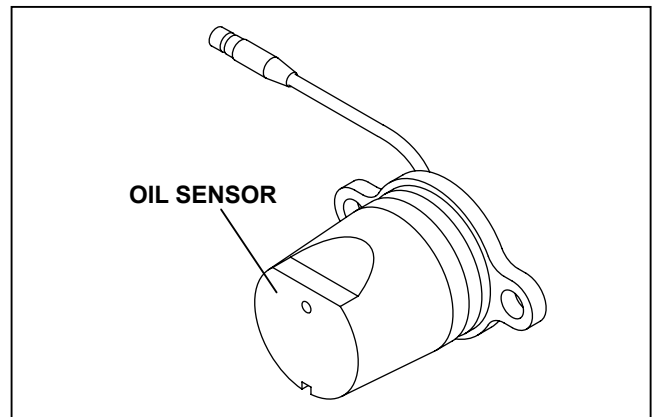

10-2 CONSTRUCTION AND OPERATION

The oil sensor is composed of the float, permanent magnet incorporated into the float and the oil sensor. In accordance with the oil level, the float moves up and down.

When the oil level is upper level, the float moves up.

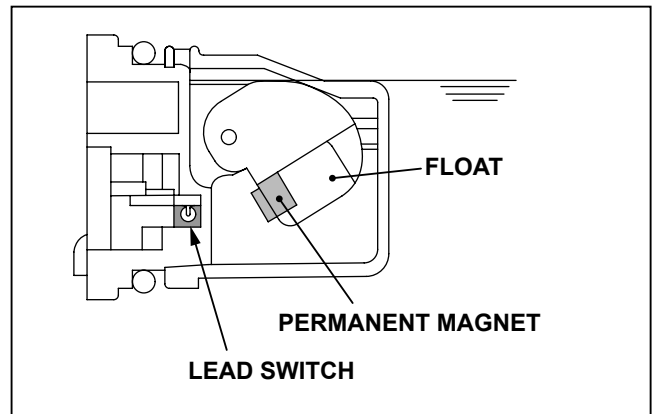

When the oil level is lower level, the float moves down.

The permanent magnet is close to the lead switch, and the lead switch is activated by the magnetic force.

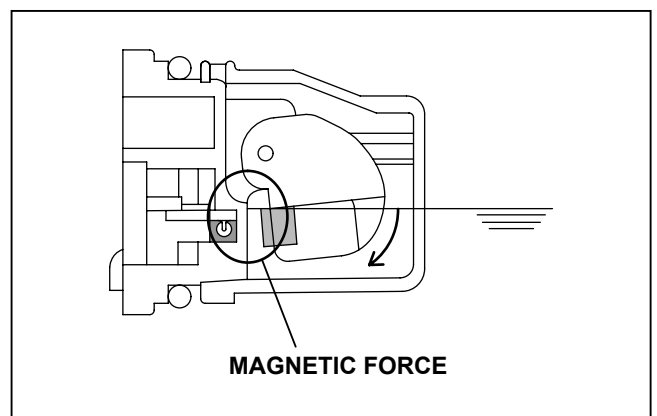

NOTE: With regards to the wiring diagram, please refer to the section 8-3 (page46).

11. AUTOMATIC DECOMPRESSION SYSTEM

11-1 FUNCTIONS AND CONSTRUCTION

EX series engines employ an automatic decompression system as a standard feature. This enables easy starting of the engine, with lighter recoil pull.

The automatic decompression system releases the compression of the engine by lifting up the exhaust valve at cranking speed. The following is the explanation of the function.

At the end of the compression process, the release lever lifts up the rocker arm (exhaust) which in turn opens up the exhaust valve slightly to release the compression.

The release lever has a flyweight on its end and another end of the lever is a crescent cam.

When the engine is cranked, the crescent cam projects above the cam profile and lifts up the rocker arm (exhaust) because the force of the return spring on the weight is larger than the centrifugal force on the weight.

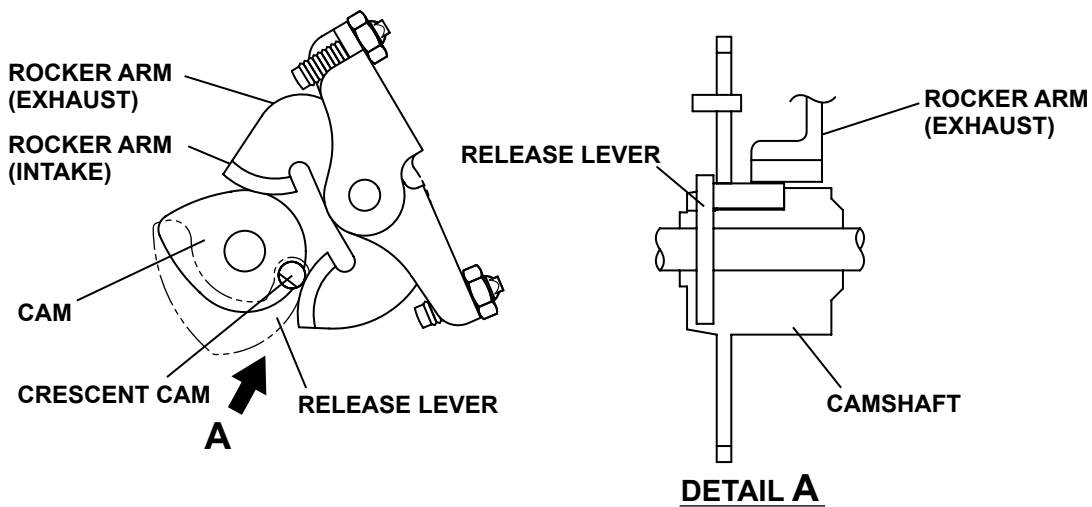

When the cranking speed reaches a specified r.p.m., the crescent cam is retracted under the cam profile because the centrifugal force applied to the flyweight becomes larger than the force of the return spring on the weight and thus it is shifted to the position shown in the illustration below.

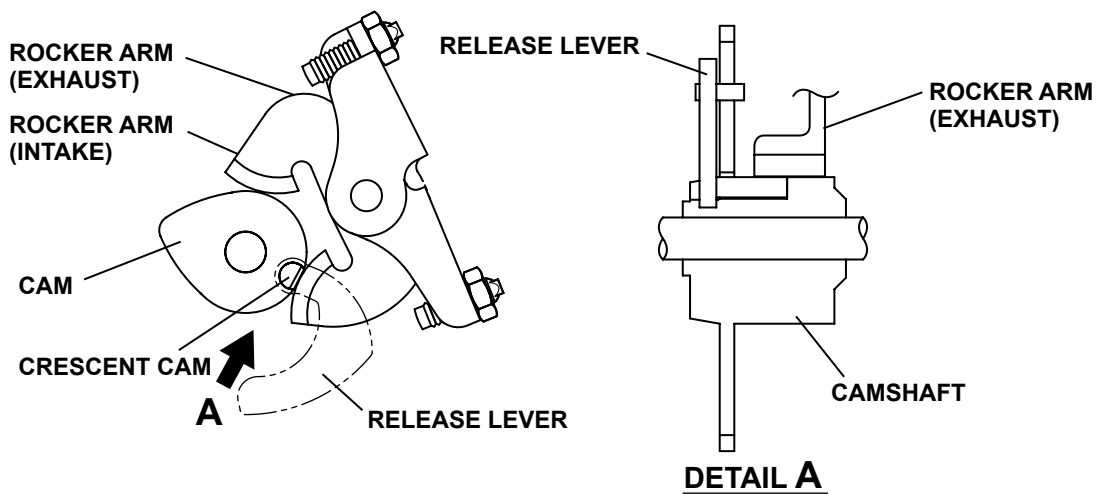

11-2 INSPECTION

When assembling the release lever, make sure that it works smoothly.

12. CARBURETOR

12-1 SPECIFICATIONS

A/C Type	Urethane foam element
Main Jet	98.0
Pilot Jet	40.0
Pilot Screw Turning	1-1/2

12-2 FUNCTIONS AND CONSTRUCTION

12-2-1 FLOAT SYSTEM

The float chamber is located below the carburetor body. Through the operation of the float and the needle valve, the float chamber maintains a constant fuel level while the engine is working.

The fuel flows from the tank into the float chamber through the needle valve. When the fuel rises to a specific level, the float rises. When the buoyancy of the float is balanced with the fuel pressure, the needle valve shuts off the fuel passage, thereby maintaining the fuel at the predetermined level.

12-2-2 PILOT SYSTEM

The pilot system supplies fuel to the engine during idling and low-speed operation.

Fuel is initially metered by the main jet and then metered once again by the pilot jet. At the pilot jet, the fuel is mixed with air metered by the pilot air jet and then the fuel/air mixture is fed to the engine through the pilot outlet and the bypass. During idling, fuel is fed to the engine mainly through the pilot outlet.

12-2-3 MAIN SYSTEM

The main system feeds fuel to the engine at medium and high speed operation.

Fuel is metered by the main jet and flows into the main nozzle. Air metered by the main air jet is mixed with fuel through the bleed holes of the main nozzle. The fuel/air mist is injected into the Venturi and mixed once again with air from the air cleaner. This fuel/air mixture is now of optimum concentration and is fed into the combustion chamber of the engine.

12-2-4 CHOKE SYSTEM

The choke system is for easier start of the engine in cold weather conditions.

When the engine is started with a closed choke, the negative pressure applied to the main nozzle increases. This causes a larger amount of fuel to be drawn into the carburetor, which in turn makes it easier to start the engine.

FUEL SYSTEM OUTLINE

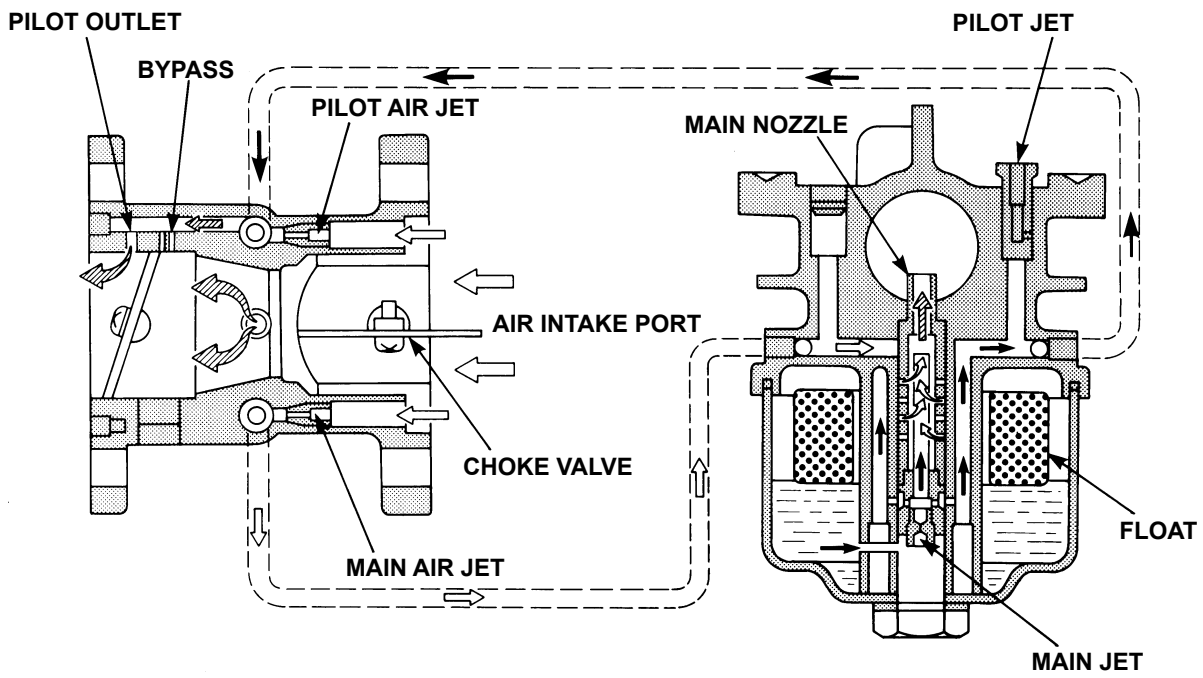
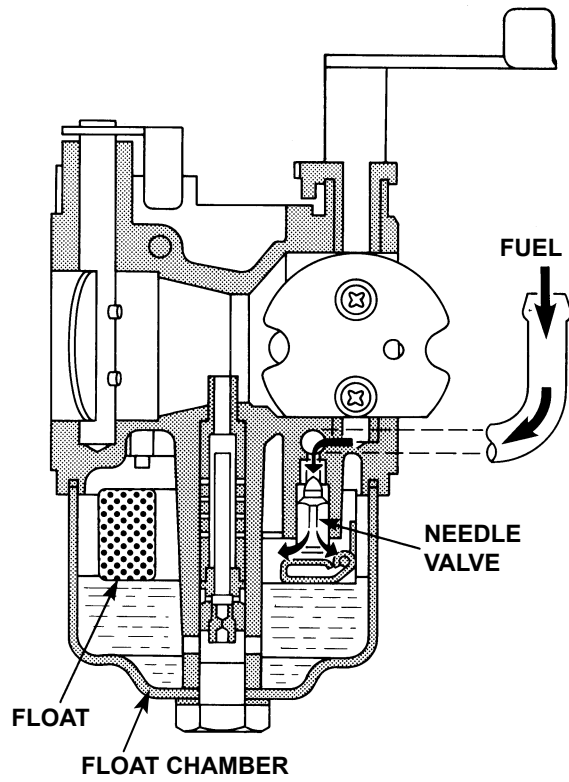

12-3 DISASSEMBLY AND REASSEMBLY

Mechanical failures aside, most carburetor malfunctions occur when the fuel/air ratio of the mixture is not correct. This is usually caused by clogged jets, air passages and fuel passages, or by variations in the fuel level. To get the best possible performance from the carburetor, ensure that the each passages are kept clean so that air and fuel can flow freely through them.

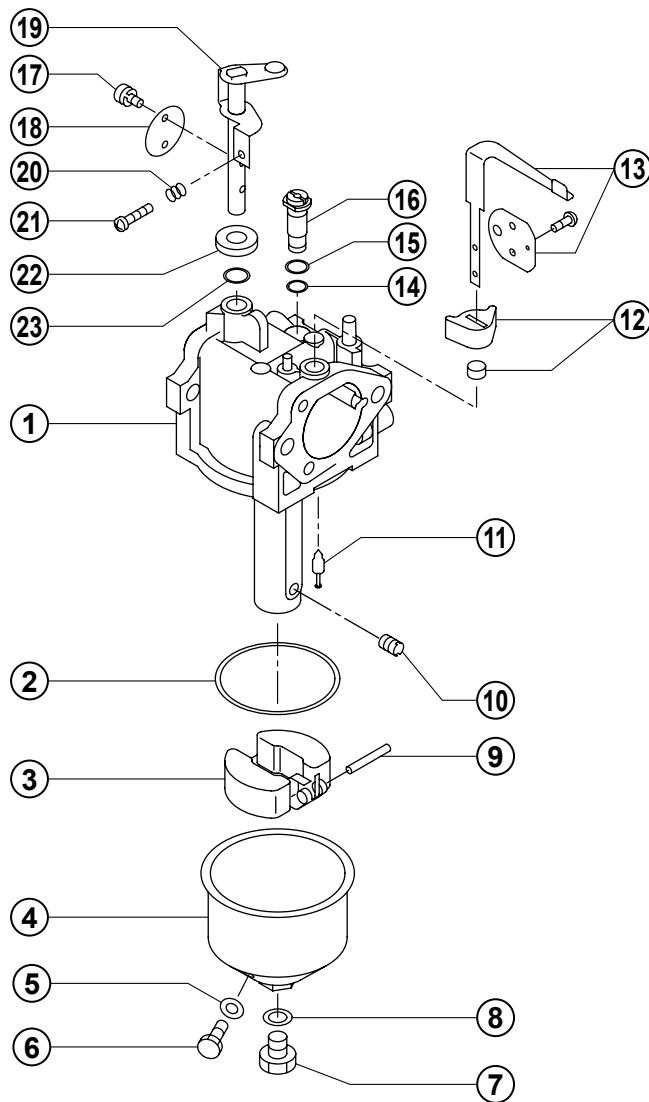

The procedures for overhauling the carburetor are described below.

12-3-1 THROTTLE SYSTEM

- (1) When the throttle stop screw ⑳ is removed, the spring ㉑ can be taken out.
- (2) Remove the phillips screw ⑰ and the throttle valve ⑱, then take out the throttle shaft ⑲.
When removing the throttle valve, take care not to damage the valve edge.

12-3-2 CHOKE SYSTEM

- (1) Remove the choke valve ⑬. Then pull out the choke shaft ⑫.
- (2) When reassembling the choke shaft, be sure to position the cutout on the choke valve facing the pilot air jet.

12-3-3 PILOT SYSTEM

- (1) Remove the pilot jet ⑯. Use the correct tool so as to avoid damaging the jet.
- (2) When reassembling the pilot jet, be sure to firmly tighten it, otherwise fuel may leak, leading to engine malfunction.

12-3-4 MAIN SYSTEM

- (1) Remove the screw ⑦ and remove the float chamber body ④.
- (2) Remove the gasket ② from the body ①.
- (3) Remove the main jet ⑩ from the body ①.
- (4) When reassembling the main system, be sure to fasten the main jet firmly to the body, otherwise the fuel concentration in the fuel/air mixture may become too rich, leading to engine malfunction.
- (5) The tightening torque of the screw ⑦ is 9 N·m (90 kgf·cm / 6.5 ft·lb.). Be sure not to forget to mount the washer.

12-3-5 FLOAT SYSTEM

- (1) Take out the float pin ⑨ and then remove the float ③ and the needle valve ⑪.
 - ※ Since the needle valve ⑪ is linked to the float ③, take care when assemble.
 - ※ Do not use drill or similar objects for cleaning the jets, as these are likely to damage the orifices, which in turn can impair fuel flow. Use compressed air to clean the jets.
 - ※ The float pin is pressed into the carburetor body. When removing the needle valve and the float, a rod or a similar tool slimmer than the float pin should be used. Tap the reverse side gently and remove.

13. RECOIL STARTER

Tools to be prepared: Driver, Pinchers (Pliers), Protective Glasses and Work gloves.

WARNING
Before starting the disassembly, make sure to wear the protective glasses.

13-1 DISASSEMBLY STEPS

- (1) Relieve the spring power.
 - 1: Hold the starter knob and extract the starter rope.
 - 2: Extract the rope fully and hold the rope so that the knot of the rope in the reel makes a straight line with the rope guide.
 - 3: Hold the reel with the thumbs of both hands firmly so that the rope will not be wound back.
 - 4: Pull out the knot of the rope out of the reel, and unfasten the knot and pull it out toward the starter knob. (2 people required)
 - 5: By controlling the reel with the thumbs of both hands, unwind the reel gently until the rotation of the reel stops.

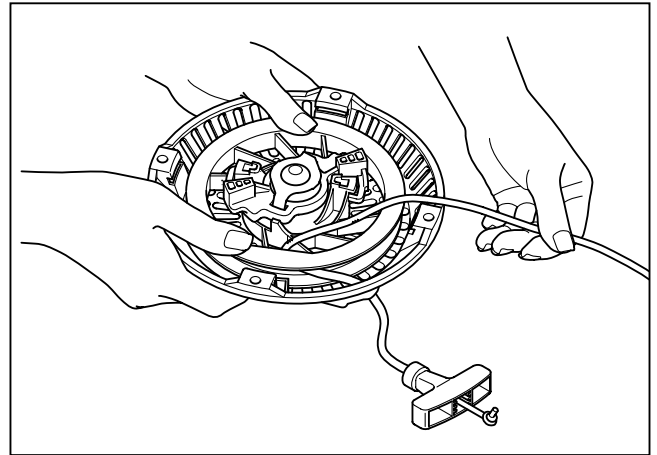

WARNING
The spring power is at its maximum when the rope is fully extracted. Do not put off your hand nor loosen the pressure of your finger suddenly.

- (2) Remove the component parts.
 - 1: Fix the case and loosen the set-screw.
 - 2: Remove the set-screw, the friction plate, the friction spring and the latchet in the order from the above.
- (3) Remove the reel.
 - 1: Hold the reel lightly so that it will not float. Move the reel clockwise and counter-clockwise about a quarter circle for several times until it moves smoothly.

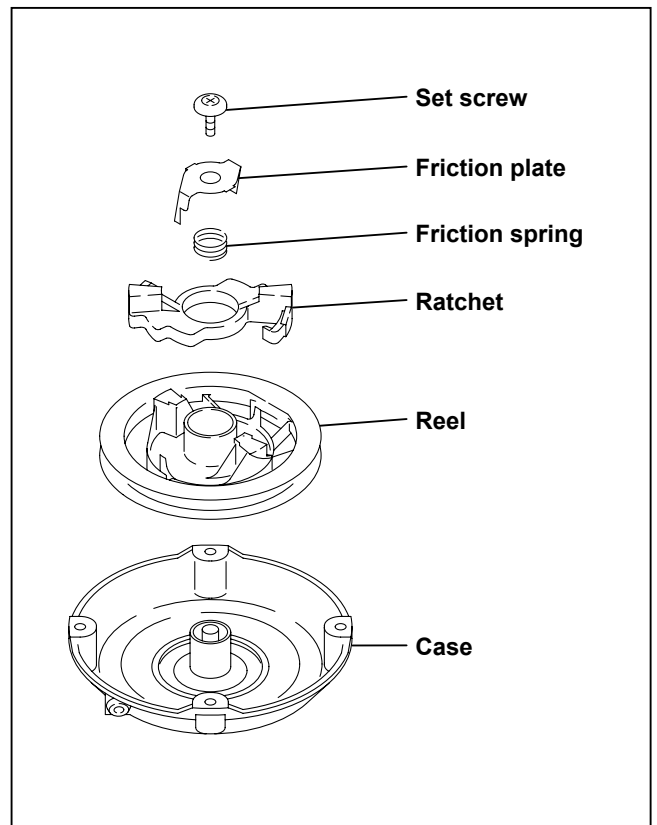

- 2: Hold up the reel gradually and slowly, and remove it from the case.
- 3: If the spiral spring in the reel likes to jump out of the reel, stop the procedure and push the reel against the case to redo the step of section (3)-1 and (3)-2.

WARNING
Since the spiral spring is set in the reel, do not drop or shake it. Put it on a flat place.

Disassembly is completed.

WARNING
Before starting the assembly, make sure to wear the protective glasses.

13-2 ASSEMBLY STEPS

- (1) Setting the reel into the case.
 - 1: Peep at the boss of reel to check the inner end of the spring.
 - 2: Hook the inner end of spring to the hook of case and put the reel into the case. (Figure 13-2-A)
- (2) Assemble the component parts.
 - 1: Put the ratchet in the reel so that the receiving area of the reel is within the area illustrated in Figure 13-2-B.
 - 2: Assemble the friction spring to the shaft in the case.
 - 3: Insert the legs of friction plate (2 places) in ratchet holes. (Figure 13-2-C)
- (3) Tighten the center screw.
 - (2 people required for this step.)
 - 1: Adjust the tip of center shaft to the hole of friction plate and compress the friction spring by pushing the friction plate with your fingers.
 - 2: Tighten the center screw counterclockwise (as it is reverse screw).

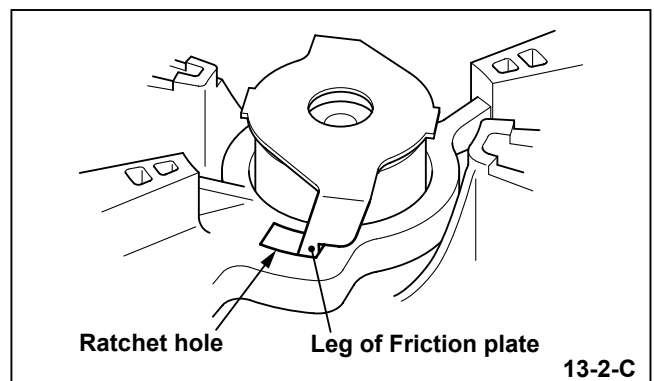
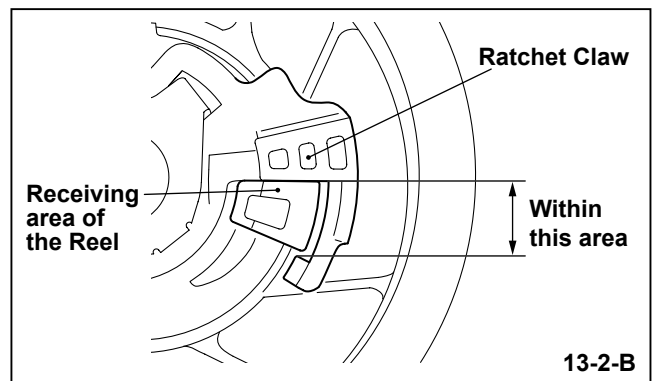
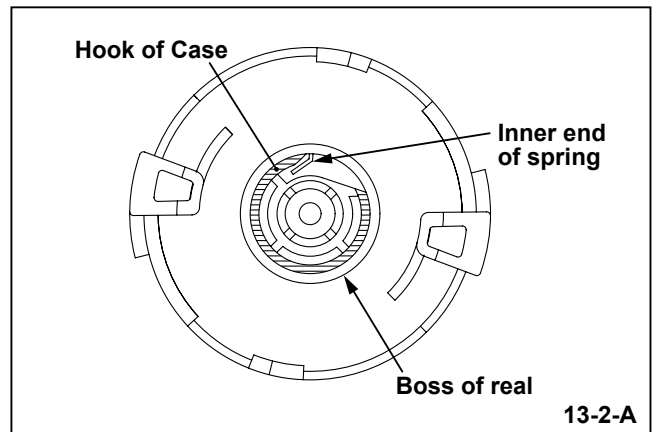

WARNING
Wear work gloves during operation to avoid a possible injury by a sharp edge of the friction plate.

(4) Wind the spiral spring.

-1: Hold the case tightly and rotate the reel counterclockwise until it stops.
(It stops when it is wound approx. 6 turns.)

-2: Turn back the reel slowly by approx. 3/4 turns and hold the reel at the position where the rope hole of the reel and the rope guide of the case are aligned.

WARNING

The spring power is at its maximum when the reel is being wound. Do not put off your hand nor loosen the pressure of your finger unintentionally.

(5) Setting the rope. (2 people required)

-1: Pass the rope end through the rope guide to the rope hole on the reel and make a knot as shown in Figure 13-2-D.

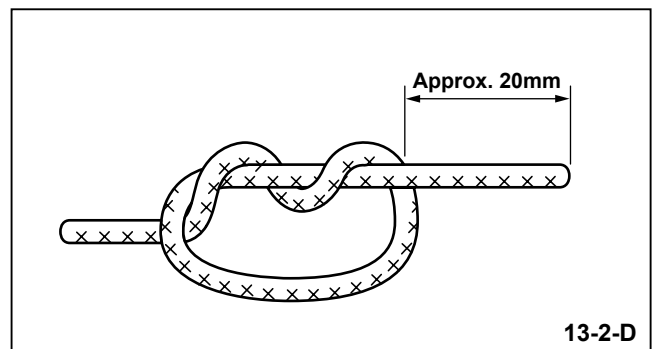

-2: Put the rope-end-knot in the reel paying attention that it will not touch the case. (Figure 13-2-E)

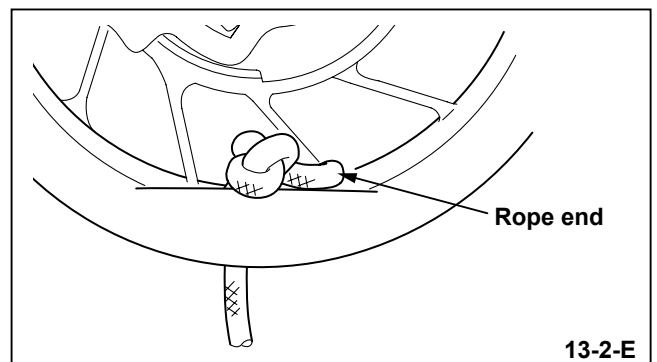

-3: Hold the rope firmly with the hand at the position about 50cm from the rope guide and keep the rope slightly pull so that the rope will not be wound in.

-4: Release the hand of the reel gently and wind the rope slowly by the winding power of the spring until the knob reaches the rope guide.

Assembly is completed.

*The disassembly and the reassembly have been completed, however carry out the following to check if the necessary components have surely been assembled.

13-3 CHECK AFTER REASSEMBLY

- (1) Pull the starter knob a few times to check if :
 - A. The starter knob is too heavy to pull, check that each part has been assembled as specified.
 - B. The ratchet does not function, check if parts such as friction spring have been missing.
- (2) Pull the starter knob and pull out the rope fully to see if:
 - A. If the starter rope remains in the groove of the reel, immoderate strain is imposed to the spiral spring. Pull out the rope by approx. 30 cm, and pull it out toward inner side of the recoil starter with holding the reel firmly with your thumb.
Then rewind the reel 1 to 2 turns while applying a brake with your thumb.
 - B. The return power of the rope is weak or the starter knob droops on the way, apply grease or mobile oil to the rotating and the frictional parts.
If the problem is not solved, wind the reel 1 to 2 turns. (In this case, check that the spring is not over-stressed.)
 - C. The spring comes off with a sound and the starter rope cannot be wound in the reel, reassemble the starter from the beginning.

13-4 OTHER GUIDES

- (1) When the spring jumps out of the reel:

With a thin wire, make a ring whose diameter is smaller than spring housing.

Hook the outer end of the spring to the ring and re-wind the spring into the wire ring as shown in Figure 13-4-A, then put it into the spring housing of the reel.

Remove the ring slowly while holding down the spring with fingers so as not to come out of place.

The ring can easily be removed by prying it with the tip of a screwdriver.

If the wire ring is not available, re-wind the spring directly into the housing.
- (2) Lubricate the rotating and frictional parts with grease (If possible, heat-resistant type is preferable) or mobile oil when the starter is disassembled or prior to long term storage.

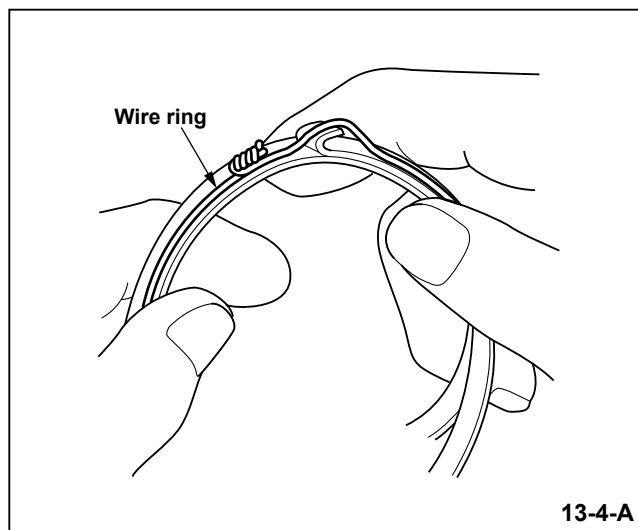

14. INSTALLATION

Installation has a decisive influence on engine life, ease of maintenance and inspection, frequency of inspection and repair, running costs and other related aspects. Before installing the engine, be sure to plan the installation with care, taking the points below into account.

14-1 INSTALLING

When installing the engine, pay special attention to the position of installation, the method for coupling with working equipment, and the foundations and supports for the engine. Position the engine so that tasks such as gasoline and oil replenishment and inspection, spark plug inspection, air cleaner maintenance, oil drainage and so on can be carried out as easily as possible.

14-2 VENTILATION

An engine requires fresh air for cooling and for burning fuel. When an engine is covered with a bonnet or is operated in an enclosed space, the temperature around the engine rises and this causes such problems as vapor lock, oil deterioration, increased oil consumption, power loss, engine seizure, and reduced engine life, making it difficult for the engine to function normally. It is thus necessary to install ducts and dampers to guide fresh air, so as not to recycle the hot air used to cool the engine and to prevent the working equipment from heating up.

Be sure to keep the engine room temperature below 50°C all year round and to prevent the accumulation of hot air in the engine room.

14-3 EXHAUST EQUIPMENT

Exhaust gas is noxious. When operating the engine indoors, make sure that exhaust gases are discharged outdoors. However, if the exhaust pipe is long, resistance increases and this lowers engine output. Therefore, the longer the exhaust pipe the larger its inner diameter should be.

Exhaust pipe length: Less than 3 m Pipe inner diameter: 30 mm

Exhaust pipe length: 3 - 5 m Pipe inner diameter: 33 mm

The ideal solution is forced exhaustion (outdoors) by installing a blower on the exhaust pipe.

※ Install a safety cover on the exhaust pipe, muffler and other related parts.

14-4 FUEL SYSTEM

If the fuel tank is detached from the engine, the height from the bottom of the fuel tank to the fuel joint of the carburetor should be between 5 cm and 50 cm.

When using a fuel pump, the bottom of the fuel tank can be up to 20 cm below the carburetor. Position the fuel tank carefully because, when it is low, fuel is not fed to the carburetor and when it is high, it can cause an overflow in the carburetor. When piping the fuel, the hose should be as short as possible and attention should be paid to heat transmission, size, bending, leakage at hose joints and so on. Care should also be taken to prevent air lock and vapor lock.

14-5 POWER TRANSMISSION TO DRIVE MACHINES

14-5-1 BELT DRIVE

Note the following:

- Use a V-belt rather than a flat belt.
 - The drive shaft of the engine must be parallel to the drive shaft of the driven machine.
 - The drive pulley of the engine must be in line with the driven pulley of the machine.
 - Install the engine pulley as close to the engine as possible.
 - If possible, span the belt horizontally.
 - Disengage the load when starting the engine.
- ※ A belt tensioner or similar should be installed if no clutch is used.

14-5-2 FLEXIBLE COUPLING

When using a flexible coupling, run-out and misalignment between the driven shaft and the engine shaft should be minimized.

The permissible margin of run-out and misalignment is specified by the flexible coupling manufacturer.

15. TROUBLESHOOTING

If the engine shows any sign of malfunction, the cause should be determined immediately and appropriate countermeasures should be taken to prevent the problem from worsening. This section describes certain known problems, their possible causes and appropriate countermeasures. Note, however, that the list of problems presented here is not all. Generally speaking, since there is the possibility of multiple causes for a single problem, please use your experience and common sense when deciding on what action to take.

15-1 ENGINE

The following three conditions must be fulfilled for satisfactory engine start.

1. The cylinder filled with a proper fuel-air mixture.
2. Good compression in the cylinder.
3. Good spark, properly timed, to ignite the mixture.

The engine cannot be started unless these three conditions are met. There are also other factors which make engine start difficult, for example, a heavy load on the engine when it is about to start at low speed, and a high back pressure due to a long exhaust pipe.

Problem and possible cause		Remedy	
Starting difficulties	1. Ignition system problems	1) Spark plug <ul style="list-style-type: none"> • Improper spark plug gap • Insulation defect • Carbon deposits 	Adjust the gap Replace Clean
		2) Ignition coil <ul style="list-style-type: none"> • Insulation defect or discontinuity • Poor contact or broken wire 	Replace Repair or replace
		3) Improper air gap between ignition coil and flywheel	Adjust
	2. Fuel system problems	1) No fuel in fuel tank	Refill
		2) Fuel hose clogged or pinched	Clean or replace
		3) Air in fuel lines	Check and retighten joints
		4) Poor quality gasoline or water in gasoline	Replace
		5) Carburetor <ul style="list-style-type: none"> • Overflow • Clogged or damaged • Throttle valve malfunction (does not close fully) 	Adjust Overhaul Check and adjust
	3. Engine core components problems	1) Insufficient tightening of cylinder head bolts	Check and retighten
		2) Wearing of piston, piston rings and/or cylinder	Repair or replace
		3) Improper contact of valve and seat	Repair
		4) Valve sticking	Repair
		5) Improper valve clearance	Adjust
6) Leakage from intake manifold gasket		Retighten; replace gasket	
7) Leakage from carburetor gasket		Retighten; replace gasket	
8) Insufficient tightening of spark plug	Retighten		

Problem and possible cause			Remedy
Poor output	1. Insufficient compression	1) Loosen spark plug	Retighten; replace gasket
		2) Leakage from cylinder head gasket	Retighten; replace gasket
		3) Piston ring seizure or wear	Replace
		4) Piston or cylinder wear	Repair or replace
		5) Incorrect valve and seat contact	Repair or replace
		6) Valve stem seizure	Repair or replace
		7) Improper valve clearance	Adjust
	2. Ignition system problems	1) Faulty spark plug	Replace
		2) Faulty ignition coil	Replace
		3) Improper air gap between ignition coil and flywheel	Adjust
		4) Demagnetization (flywheel magneto)	Replace
	3. Fuel system malfunction	1) Carburetor clogged	Overhaul, clean
		2) Fuel strainer and/or hose clogged	Clean or replace
		3) Air in fuel lines	Check and retighten joints
4) Poor quality gasoline or water in gasoline		Replace	
4. Low air intake volume	1) Air cleaner clogged	Clean or replace	
	2) Throttle valve malfunction	Repair or replace	
Overheat	1. Engine	1) Cooling air flow obstructed at inlet or cylinder baffle portion	Clean
		2) Poor quality engine oil	Replace
		3) Lean fuel/air mixture	Check and adjust carburetor
		4) Excessive back pressure of exhaust system	Check and clean or replace
		5) Overloading	Adjust to rated load
Rough Idling	1. Carburetor system	1) Low idling speed	Adjust
		2) Slow system passage clogged	Check and clean
	2. Intake system	1) Air mixing from air intake system joints	Check and tighten; replace gasket
	3. Cylinder head	1) Gasket faulty (blow-by)	Replace
	4. Valve system	1) Improper valve clearance	Adjust
		2) Leakage from valve seat	Repair
		3) Excessive clearance between valve stem and guide	Replace
	5. Ignition system	1) Weak spark	Check; adjust or replace plug

Problem and possible cause		Remedy	
Excessive engine oil consumption	1. Oil leakage	1) Loose oil drain plug	Tighten
		2) Faulty oil drain gasket	Replace
		3) Loose main bearing cover bolts	Tighten
		4) Faulty main bearing cover gasket	Replace
		5) Crankshaft oil seal (front, rear) defect	Replace
	2. Oil up	1) Faulty piston oil ring	Replace
		2) Piston ring seizure, wear or poor contact	Replace
		3) Excessive wear of piston and/or cylinder	Replace
		4) Faulty stem seal	Replace
		5) Excessive oil level	Adjust oil level
		6) Breather defect	Repair or replace
High fuel consumption	1. Fuel system	1) Clogged air cleaner	Clean or replace
		2) Faulty needle valve and/or high fuel level in float chamber	Repair or replace
		3) Choke does not open fully	Repair or replace
	2. Engine core components	1) Low compression	Check and repair
		2) Overcooling	Check and adjust load and/or engine speed
Abnormal engine noise	1. Ignition system problems	1) Loose ignition system wiring	Inspect and tighten
		2) Improper or faulty spark plug	Clean or replace
	2. Fuel system problems	1) Lean or rich fuel/air mixture	Clean, adjust or replace carburetor
		2) Carburetor contamination	Overhaul or clean
		3) Dirty or clogged fuel lines	Clean or replace
		4) Air mixing from air intake system joints	Tighten; replace gasket
	3. Cylinder head	1) Carbon deposit in combustion chamber	Clean
		2) Leakage from cylinder head gasket	Replace
	4. Valve system problems	1) Improper valve clearance	Adjust
		2) Valve heat deterioration	Replace
		3) Worn or broken valve spring	Replace
		4) Improper valve timing	Adjust

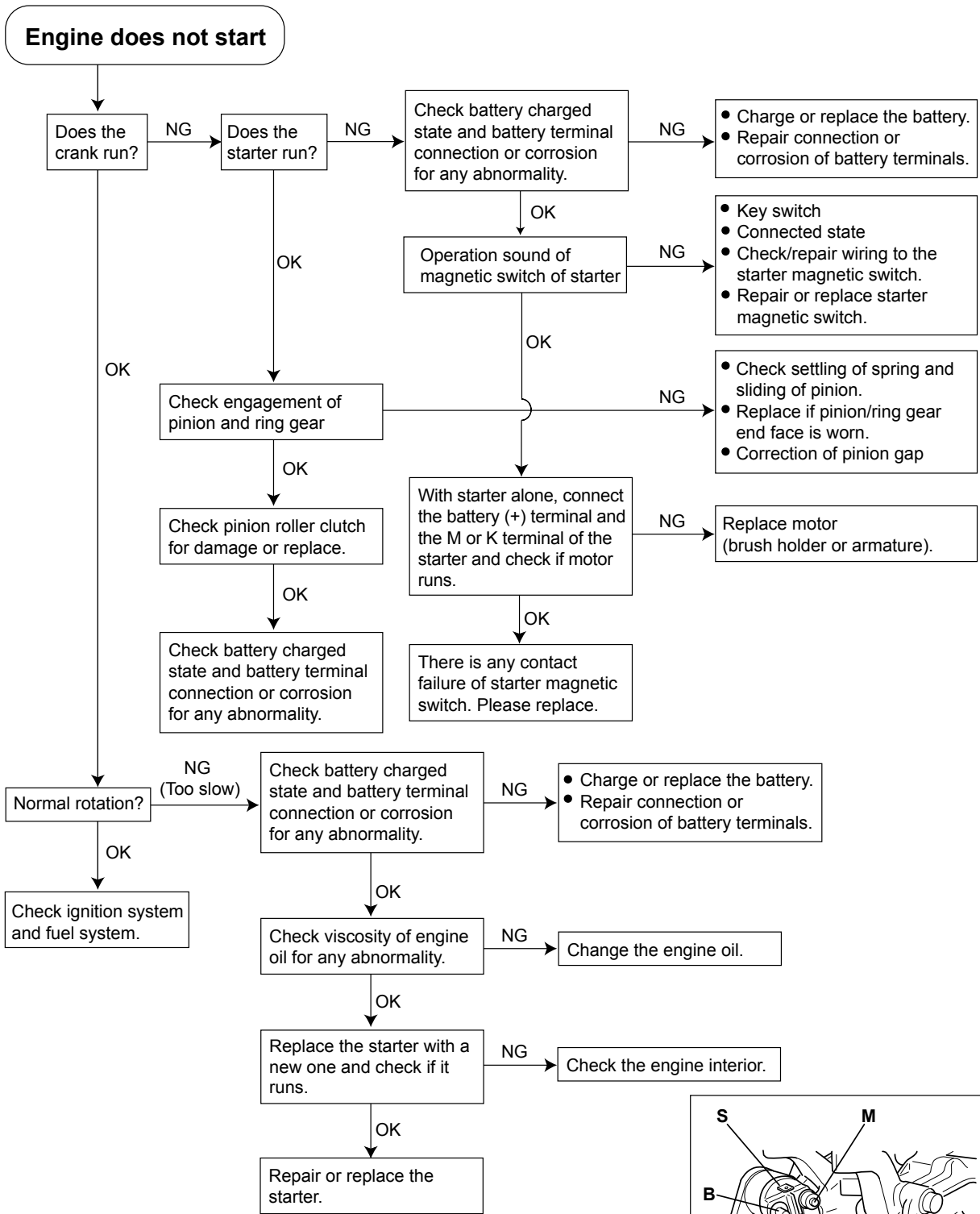

ELECTRIC STARTER

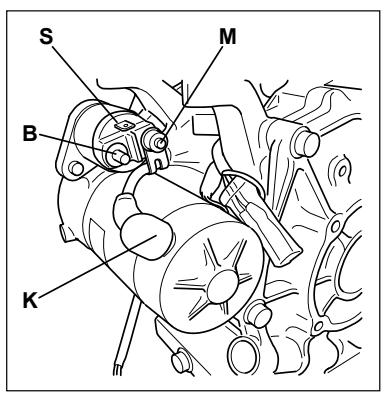

※ When the starter continuously runs
(Immediately remove the (-) terminal of the battery)

Motor does not stop even when the key switch is turned off. → Repair or replace the key switch or starter magnetic switch.

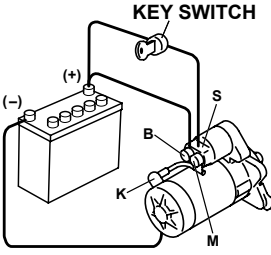
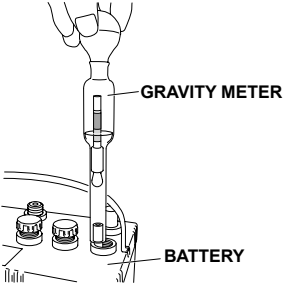

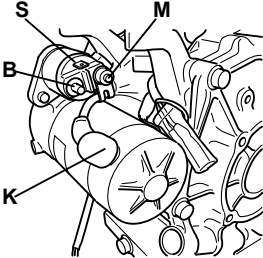
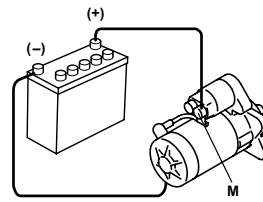
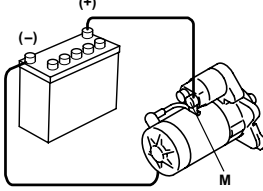
Problem and check item	Description	Diagram	Remedy
(1) Starter does not run or only "click" sound is heard.	<p>1. Checking of continuity of wiring</p> <p>Check S terminal and B terminal for deformation, looseness, rusting, or dust sticking. Carefully check inserting method of the S terminal.</p> <p>If not abnormal, set the key switch to START position while cranking (no ignition of engine) and check if voltage is applied to the S terminal and B terminal of starter motor.</p>		<p>(1) When no voltage is applied to the S terminal and B terminal, check continuity of the terminals and key switch and repair or replace if necessary.</p> <p>(2) If voltage is applied to the S terminal and B terminal, go to "2. Battery checking."</p>
	<p>2. Battery checking</p> <p>Check battery voltage and specific gravity of battery fluid.</p> <p>[Voltage] Normal value : 12.4 to 12.8V Limit (charging required) : 12.4V or lower Starting limit : 12V (at 20°C)</p> <p>[Specific gravity] Normal value : 1.22 to 1.29 Limit (Charging required) : 1.22 or lower</p> <p>[Service life] Variance in specific gravity among cell : 0.04 or more</p>		<p>(1) Charge or change the battery when voltage is lower than 12.4V or specific gravity is lower than 1.22 (at 20°C).</p> <p>(2) If the wiring and battery are normal, remove the starter and go to "3. Checking of pinion operation."</p>
	<p>3. Checking of pinion operation</p> <p>Check if the pinion operates or sound of magnetic switch contactor is heard.</p> <p>If the pinion does not operate or magnetic switch sound is not heard, check continuity of each coil of magnetic switch.</p>		<p>(1) If the pinion operates or contactor sound is heard, step to "4. Checking of magnetic switch (1)."</p> <p>(2) In case of no continuity Replace the magnetic switch.</p> <p>(3) When continuity is OK Step to "4. Checking of magnetic switch (2)."</p>
	<p>(1) Operate the magnetic switch and check B-M terminals</p>		<p>(1) In case of no continuity Contact continuity failure. Replace the magnetic switch.</p> <p>(2) When continuity is OK Step to "5. Motor checking."</p>
	<p>(2) Check the magnetic switch plunger and bobbin interior for dust sticking or rusting.</p>		<p>(1) Clean the plunger. If the bobbin interior is contaminated, replace the magnetic switch.</p>
<p>5. Motor checking</p>	<p>Connect the (+) side of the battery to the M terminal of magnetic switch and check if the motor runs.</p>		<p>(1) If the motor does not run, check electric circuit inside the motor, field coil, armature, and brush and replace faulty parts.</p>

Problem and check item		Description		Remedy
(2) Starter runs but engine not	Check engaged state of pinion and ring gear.	Motor idles and engine does not run.	<p>MAGNETIC SWITCH CABLE To KEY SWITCH (TERMINAL "ST") EARTH WIRE BATTERY</p>	(1) Remove and check the starter. Check or replace the pinion clutch if necessary. (2) Check battery charged state and battery terminal connection or corrosion for any abnormality.
		If pinion and ring gear do not engage with each other and abnormal noise is heard between end faces of pinion and ring gear, check the starter pinion and ring gear.	<p>RING GEAR PINION GEAR</p>	(1) Remove the starter and check pinion and ring gear end faces. If worn, replace the pinion and ring gear. (2) In case of sliding fault of the pinion, correct it. (3) If shift lever or spring is deformed, replace it.
(3) Both starter and engine run, but the engine does not start.	Check if the rotation speed is normal or slow. If slow, check the battery and engine oil viscosity.	<p>MAGNETIC SWITCH CABLE To KEY SWITCH (TERMINAL "ST") EARTH WIRE BATTERY</p>	(1) When the rotation speed is normal Check the ignition system and fuel system. (2) When the rotation speed is slow (a) Check the battery. (b) Check the viscosity of engine oil. If not normal, change the oil. (c) If both (a) and (b) are normal Remove and check the starter.	

16. STANDARD REPAIR TABLES

"STD" in the following table is the parts dimension from the brand new engine or the spare parts.

Whereas, "Limit" shows the maximum allowance for the parts to be used on the engine.

If the measurement exceeds beyond the "Limit" the part needs to be replaced and/or repaired.

16-1 STANDARD DIMENSIONS AND LIMITS OF USE

Unit: mm (in.)

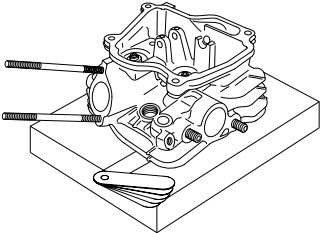
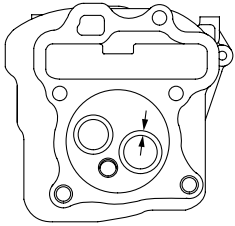
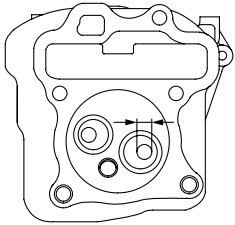
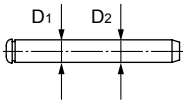
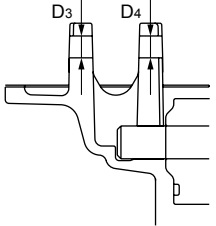
ITEM	STD	Limit
CYLINDER HEAD * Flatness 		0.05 (0.002)
* Intake/exhaust valve seat contact width 	Intake Exhaust.	0.7 - 1.0 (0.0276 - 0.0394)
* Intake/exhaust valve guide inner diameter 	Intake Exhaust.	5.500 - 5.518 (0.2165 - 0.2172)
* Rocker arm pin outer diameter 	Pin outer diameter D1, D2	5.970 - 5.980 (0.235 - 0.235)
* Rocker arm pin support inner diameter 	Support inner diameter D3, D4	6.00 - 6.018 (0.236 - 0.237)

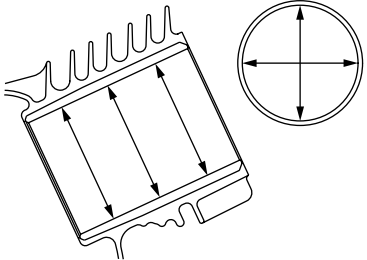
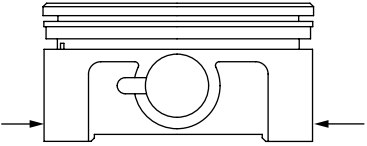
ITEM	STD	Limit
<p>CYLINDER</p> <p>* Inner diameter</p>  <p>* Roundness after re boring</p> <p>* Cylindricity after re boring</p>	Standard	75.000 - 75.019 (2.9528 - 2.9535)
	First re boring	75.250 - 75.269 (2.9626 - 2.9633)
	Second re boring	75.500 - 75.519 (2.9724 - 2.9732)
		Less than 0.01 (0.0004)
		Less than 0.015 (0.0006)
<p>PISTON</p> <p>* Outer diameter at skirt in thrust direction</p> 	Standard	74.980 - 75.000 (2.9520 - 2.9527)
	Oversize +0.25	75.230 - 75.250 (2.9618 - 2.9626)
	Oversize +0.50	75.480 - 75.500 (2.9717 - 2.9724)

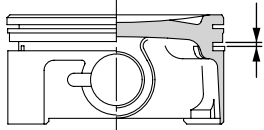
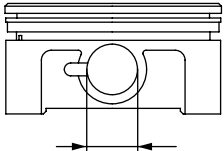
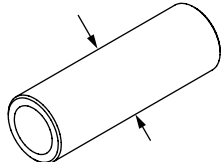
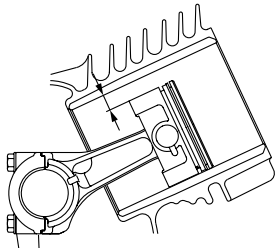
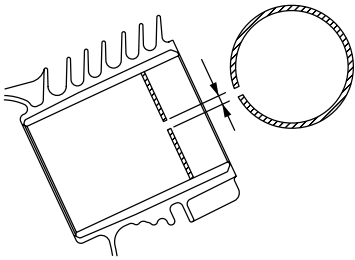
ITEM		STD	Limit
PISTON * Ring groove side clearance 	Top	0.035 - 0.080 (0.0014 - 0.0031)	0.15 (0.0059)
	Oil ring (three-piece)	0.0100 - 0.205 (0.0004 - 0.0081)	—
* Piston pin hole 		17.991 - 18.009 (0.7083 - 0.7090)	18.035 (0.7224)
* Piston pin outer diameter 		17.992 - 18.000 (0.7083 - 0.7087)	17.960 (0.7071)
* Clearance between piston and cylinder at skirt 		0.065 - 0.104 (0.0026 - 0.0041)	0.25 (0.010)
* Piston ring end gap 	Top	0.1 - 0.3 (0.0039 - 0.0118)	1.5 (0.0591)
	Oil ring	0.2 - 0.7 (0.0078 - 0.0276)	1.5 (0.0591)

Unit: mm (in.)

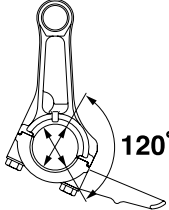
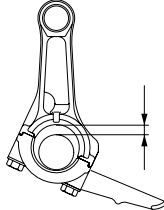
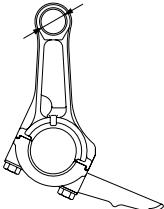
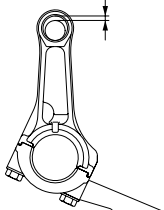
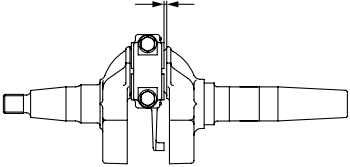
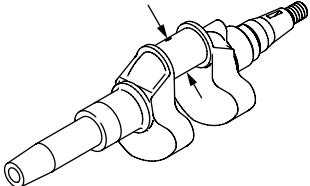
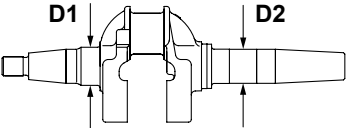
ITEM	STD	Limit
CONNECTING ROD * Large end inner diameter 	34.500 - 34.516 (1.3386 - 1.3392)	34.1 (1.3425)
* Clearance between large end and crank pin 	0.020 - 0.049 (0.0008 - 0.0019)	0.2 (0.0078)
* Small end inner diameter 	18.010 - 18.021 (0.7091 - 0.7095)	18.08 (0.7118)
* Clearance between small end and piston pin 	0.010 - 0.029 (0.0004 - 0.0011)	0.12 (0.0047)
* Large end side clearance 	0.100 - 0.780 (0.0040 - 0.307)	1.0 (0.0394)
CRANKSHAFT * Crank pin outer diameter 	34.467 - 34.480 (1.3570 - 1.3575)	34.35 (1.3524)
* Journal outer diameter 	D1	29.991 - 30.000 (1.1807 - 1.1811)
	D2	29.988 - 29.997 (1.1806 - 1.1810)

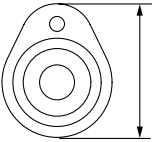
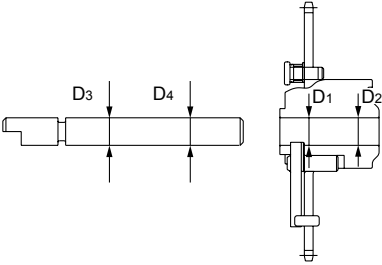
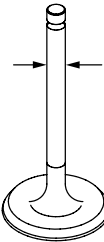
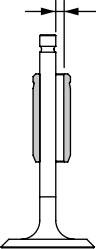
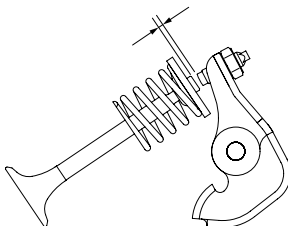
ITEM	STD	Limit	
<p>CAMSHAFT</p> <p>* Cam peak height (intake and exhaust)</p>  <p>* Cam sprocket inner diameter</p> <p>* Pin (cam sprocket) outer diameter</p> 	Cam peak height	29.431 - 29.531 (1.1587 - 1.1626)	29.38 (1.1567)
	Cam inner diameter D ₁ ,D ₂	9.0 - 9.036 (0.3543 - 0.3557)	9.05 (0.3563)
	Pin outer diameter D ₃ ,D ₄	8.953 - 8.975 (0.3525 - 0.3533)	8.95 (0.3524)
<p>INTAKE/EXHAUST VALVES</p> <p>* Valve stem outer diameter</p>  <p>* Clearance between valve stem and valve guide</p>  <p>* Valve clearance (in cold state)</p> 	Intake	5.440 - 5.455 (0.2142 - 0.2148)	5.35 (0.2106)
	Exhaust	5.426 - 5.444 (0.2136 - 0.2143)	5.35 (0.2106)
	Intake	0.045 - 0.078 (0.0018 - 0.0031)	0.3 (0.0118)
	Exhaust	0.056 - 0.092 (0.0022 - 0.0036)	0.3 (0.0118)
	Intake	0.11 - 0.16 (0.0043 - 0.0063)	
	Exhaust	0.11 - 0.16 (0.0043 - 0.0063)	

Unit: mm (in.)

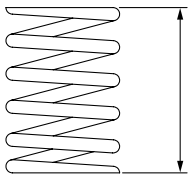
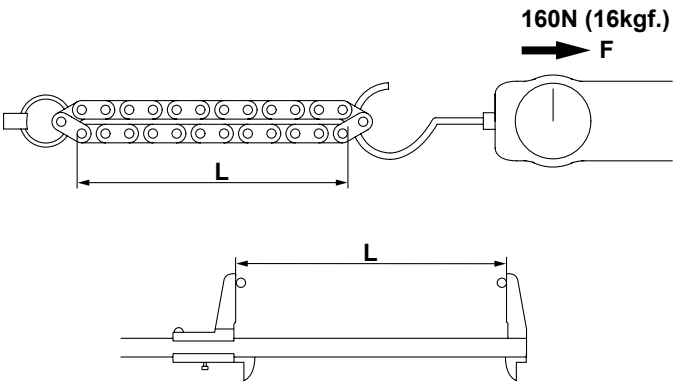
ITEM	STD	Limit
VALVE SPRING FREE LENGTH 	27.4 (1.0787)	
VALVE SEAT ANGLE (INTAKE AND EXHAUST) * Valve cutter angle (a) * Valve contact width (b)	Intake Exhaust	a: 90° b: 0.7 - 1.0 (0.0276 - 0.0394) 2.0 (0.0787)
CHAIN LENGTH 	307.1 (12.0906)	310.6 (12.2284)

Compression pressure	(kg·cm ² / 500 rpm)		5.0
Fuel consumption	Continuous load / 3600 rpm	(L / Hr)	3.0
Lubricant	Capacity	(L)	1.0
	Efficacy	(mL)	500
	Consumption	(mL / Hr)	8 - 13

※ Oil consumption has been measured under-following condition :

- Good break-in operation has been finished.
- Oil : 10W-30 (Grade SE)
- Load : Continuous load / 3600 rpm

16-2 TIGHTENING TORQUE

ITEM			Tightening Torque		
			N•m	kgf•cm	ft•lb.
Cylinder head bolts	M8 × 68 flange bolt	Re-use	25.0 - 27.0	250 - 270	18.1 - 19.5
		When replace to new cylinder head and flange bolts	28.0 - 30.0	280 - 300	20.3 - 21.7
	M8 × 35 flange bolt	17.0 - 19.0	170 - 190	12.3 - 13.7	
Connecting rod cap bolts			17.0 - 20.0	170 - 200	12.3 - 14.5
Flywheel nut			59.0 - 64.0	590 - 640	42.7 - 46.3
Main bearing cover bolts			22.0 - 24.0	220 - 240	16.2 - 17.7
Spark plug	New		12.0 - 15.0	120 - 150	8.7 - 10.8
	Re-tightening		23.0 - 27.0	230 - 270	16.6 - 19.5
Muffler nut			18.0 - 22.0	180 - 220	13.0 - 15.9
Ignition coil			7.0 - 9.0	70 - 90	5.1 - 6.5

17. MAINTENANCE AND STORAGE

The maintenance jobs described below apply to correct use of the engine under normal conditions.

The maintenance intervals mentioned in this section are not a guarantee that no maintenance is required during those intervals.

For example, when the engine is used in dusty conditions, the air cleaner should be cleaned every day, rather than every 100 hours.

17-1 DAILY MAINTENANCE (EVERY 8 HOURS OF USE)

MAINTENANCE ITEMS	REASON / REMARKS
(1) Clean dust from engine.	(1) Dust can impair operation of various parts. Governor linkage is especially sensitive to dust.
(2) Check for fuel leakage. Tighten or replace parts, if necessary.	(2) Uneconomical and dangerous.
(3) Check all parts are securely fastened. Tighten, if necessary.	(3) Looseness can result in vibration and accidents.
(4) Check oil level and add up to full mark.	(4) Running the engine with insufficient oil can result in serious problems, including engine seizure.
(5) Check that the air cleaner element is clean. Clean or replace, if necessary.	(5) A clogged air cleaner can cause power loss and malfunction.

17-2 INSPECTION AND MAINTENANCE AFTER THE FIRST 20 HOURS

MAINTENANCE ITEMS	REASON / REMARKS
(1) Change the crankcase oil.	(1) Sludge is deposited during running-in.

17-3 INSPECTION AND MAINTENANCE EVERY 100 HOURS (EVERY 10 DAYS)

MAINTENANCE ITEMS	REASON / REMARKS
(1) Change the crankcase oil.	(1) Contaminated oil quickens wear.
(2) Clean the air cleaner.	(2) A clogged air cleaner can cause engine malfunction.
(3) Inspect the spark plug. Clean with gasoline or polish with sandpaper if dirty.	(3) A faulty spark plug can cause low power output and poor starting performance.

17-4 INSPECTION AND MAINTENANCE EVERY 100 TO 200 HOURS (EVERY MONTH)

MAINTENANCE ITEMS	REASON / REMARKS
(1) Clean the fuel strainer and fuel tank.	(1) Contaminated fuel can cause engine malfunction.
(2) Change the air cleaner element.	(2) A clogged air cleaner can cause engine malfunction.

17-5 INSPECTION AND MAINTENANCE EVERY 300 HOURS

MAINTENACE ITEMS	REASON / REMARKS
(1) Inspect the intake and exhaust valve clearance. Adjust if necessary.	(1) Incorrect clearance can cause low power output and engine malfunction.

17-6 INSPECTION AND MAINTENANCE EVERY 500 TO 600 HOURS (EVERY 6 MONTHS)

MAINTENACE ITEMS	REASON / REMARKS
(1) Remove the cylinder head and remove any carbon. (2) Disassemble and clean the carburetor.	(1) Carbon deposits can cause engine malfunction. (2) A faulty carburetor can cause engine malfunction.

17-7 MAINTENANCE EVERY 1,000 HOURS (ANNUAL MAINTENANCE)

MAINTENACE ITEMS	REASON / REMARKS
(1) Overhaul the engine. Clean and correct the engine parts, replacing if necessary. (2) Replace the piston rings. (3) Replace the fuel hose.	(1) Dirty, misaligned or worn parts can cause low power output and engine malfunction. (2) Faulty piston rings can cause low output power and engine malfunction. (3) To prevent fuel leakage and attendant dangers.

17-8 ENGINE STORAGE

- (1) Carry out the maintenance jobs described in step 16-1 above.
- (2) Drain fuel from the fuel tank and carburetor float chamber.
- (3) To prevent rust in the cylinder bore, inject oil through the spark plug hole, pull the recoil starter knob gently 2 or 3 times and then put back the spark plug.
- (4) Pull the recoil starter knob until the resistance is heavy. Leave it in that position.
- (5) Clean the exterior of the engine with an oiled cloth. Place a plastic cover or similar over the engine, and store the engine in a dry place.

PRINTED IN THE USA